

EVCK4 Cylinder Extractors

Manual for Installation, Use and Maintenance

|C|D|A|



Important

The manufacturer cannot be held responsible for injuries or losses caused by incorrect use or installation of this product. Please note that the manufacturer reserves the right to invalidate the guarantee supplied with this product following incorrect installation or misuse of the appliance or use in a commercial environment.

This appliance is not designed to be used by people (including children) with reduced physical, sensorial or mental capacity, or who lack experience or knowledge about it, unless they have had supervision or instructions on how to use the appliance by someone who is responsible for their safety.

Under no circumstances should any external covers be removed for servicing or maintenance except by suitably qualified personnel.

Appliance information:

Please enter the details on the appliance rating plate below for reference, to assist CDA Customer Care in the event of a fault with your appliance and to register your appliance for guarantee purposes.

Appliance Model

Serial Number

CE Declarations of Conformity:

This appliance has been manufactured to the strictest standards and complies with all applicable legislation, including Gas safety, Electrical safety (LVD) and Electromagnetic interference compatibility (EMC).

IMPORTANT INFORMATION FOR CORRECT DISPOSAL OF THE PRODUCT IN ACCORDANCE WITH EC DIRECTIVE 2002/96/EC.

At the end of its working life, the product must be taken to a special local authority waste collection centre or to a dealer providing appliance recycling services. Disposing of a household appliance separately avoids possible negative consequences for the environment and health. It also enables the constituent materials to be recovered, saving both energy and resources. As a reminder of the need to dispose of household appliances separately, the product is marked with a crossed-out wheeled dustbin 

Please note:

- Under no circumstances should the extractor be connected to any gas ventilation system, flue system or hot air ducting system.
- Do not vent the extractor into an attic or loft space.
- Only house the extractor in rooms with adequate ventilation. Remember that the extractor is powerful and whatever air is extracted needs to be replaced.
- Do not tile the extractor in. It should be removable for service or maintenance.
- Do not use silicone sealant to secure the hood to the wall.
- You must be able to isolate the extractor from the mains electrical supply after installation.
- Steam cleaners must not be used when cleaning this appliance.
- The performance of your extractor will vary depending on a number of factors. These include: type of extraction, length of ducting, room volume, ventilation available and cleanliness of the filters.

Using your Extractor

For best performance, you should switch on the extractor 15 minutes before starting to cook and leave it to run for approximately 15 minutes after the end of cooking.

Control Panel

- A – Light button
- B, C, D – Speed level buttons
- E – Power off button
- F – Timer button

To switch the extractor light on or off

- Press button A.

To switch on the extractor or to change the speed at any time when the extractor is running

- Press button B, C or D for the first, second or third speed level as required.

To switch the extractor off

- Press button E.

The intensive function

- The extractor is equipped with an intensive function which runs for ten minutes before returning to the previous selected speed. To activate the intensive function, press and hold button B for two seconds. Button E will flash whilst the intensive function is on. To cancel the intensive function, press button E again.

The timer

- The extractor is equipped with a timer that allows the extractor to run for 15 minutes before switching off automatically.
- To activate the timer, touch button F.

Please note

The timer cannot be activated when the intensive function is on.

The clean air function

- The extractor is equipped with a clean air function that switches on the motor for ten minutes every hour at speed one.
- To activate the clean air function, press and hold button F for two seconds when the appliance is off. To return to normal function, press the button B, C or D for the speed required. To switch off the extractor, press button E. Buttons C and F will flash whilst the motor is running, and button F will be lit during the fifty minutes when the motor is not running.

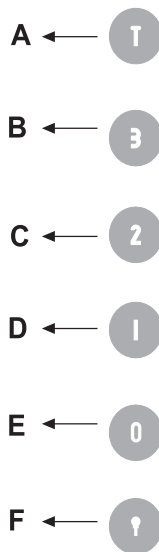

Fig. 1

Care and Maintenance

IMPORTANT : DO NOT PERFORM MAINTENANCE OR CLEANING OF THE EXTRACTOR WITHOUT FIRST SWITCHING OFF THE ELECTRICITY SUPPLY.

Cleaning

You should use a nonabrasive cleaner. Any abrasive cleaner (including Cif) will scratch the surface and could erase the control panel markings.

You can clean your extractor effectively by simply using a dilute solution of water and mild detergent and drying to a shine with a clean cloth.

Cleaning the grease filter

The grease filter should be kept clean to minimise the risk of fire.

When button A flashes every two seconds , or at least once a month you should remove and clean the grease filter with hot soapy water. You can also wash the grease filter in a dishwasher, ensuring that you place it in an upright position to prevent damage from other items in the dishwasher. After rinsing and drying, replace the filter. After the grease filter has been replaced, the electronic memory must be reset by pressing button A for approximately five seconds, until it stops flashing.

To remove the grease filter follow the steps below:

1. Push the cover panel to open the base of the extractor, as shown in fig 2.
2. Pull open the handle on the grease filter as shown in fig. 3. It will release at the handle side. Then lower the grease filter to remove it completely.

To replace the grease filter, repeat the steps in reverse.

Please note:

Cleaning the grease filter in the dishwasher may lead to discolouration. This is normal and does not constitute a fault with the appliance.

Changing the charcoal filter (re-circulating only)

When button A flashes every half second, the charcoal filters must be replaced. After the charcoal filter has been replaced, the electronic memory must be reset by pressing button A for approximately five seconds, until it stops flashing.

To attach a new charcoal filter, first open the body of the extractor and remove the grease filter as shown in figures 2 and 3. Then offer up the charcoal filter into the frame as shown in figure 4 until it locks into place. Repeat with the other charcoal filter, then close the body of the extractor.



Fig. 2

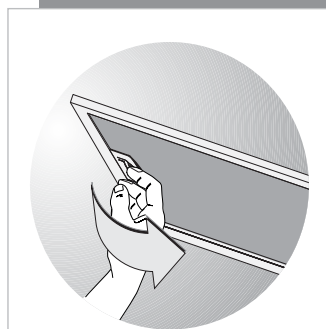

Fig. 3

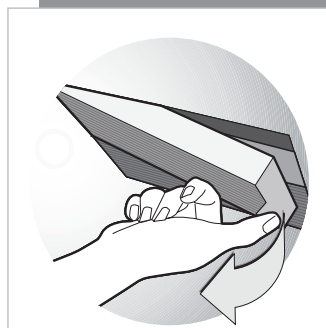

Fig. 4

Changing the Light

IMPORTANT: DO NOT PERFORM MAINTENANCE OR CLEANING OF THE EXTRACTOR WITHOUT FIRST SWITCHING OFF THE ELECTRICITY SUPPLY.

DO NOT CHANGE THE LIGHT BULB IMMEDIATELY AFTER USE AS THE BULB WILL BE HOT. ALLOW IT TO COOL BEFORE REMOVING IT.

Open the base of the extractor as described above and then press downwards on the light housing as shown in figure 5 before removing the bulb. Refit the new bulb taking care not to touch the glass (Fingerprints will lead to premature failure of the bulb).

Do not touch bulbs or adjacent areas during or straight after prolonged use of the lights.

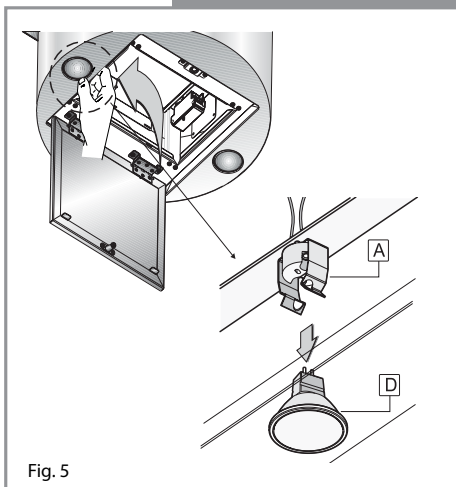

Fig. 5

Mains Electricity Connection

THIS APPLIANCE MUST BE CONNECTED TO THE MAINS SUPPLY BY A COMPETENT PERSON, USING FIXED WIRING VIA A DOUBLE POLE SWITCHED FUSED SPUR OUTLET AND PROTECTED BY A 3A FUSE.

We recommend that the appliance is connected by a qualified electrician, who is a member of the N.I.C.E.I.C. and who will comply with the I.E.E. and local regulations.

The wires in the mains lead of this appliance are coloured in accordance with the following code:

BLUE = NEUTRAL, BROWN = LIVE.

As the colours of the wires in the mains lead for the appliance may not correspond with the coloured markings identifying the terminals connecting to the fused spur, proceed as follows:

- The wire which is coloured blue must be connected to the terminal marked N (Neutral), or coloured black.
- The wire which is coloured brown must be connected to the terminal marked L (Live), or coloured red.

NOTE: USE A 3A FUSE

Assembly and electrical connection should be carried out by competent personnel.

When installing this product we recommend you seek the help of another individual.

IMPORTANT: THIS APPLIANCE IS A CLASS II APPLIANCE (DOUBLE INSULATED) AND IS NOT INTENDED TO BE EARTHED. DO NOT FIT AN EARTH LEAD TO THIS EXTRACTOR.

Do not mount the isolation switch behind the chimney section. It is a requirement that you must be able to isolate the extractor from the mains electrical supply after installation.

This appliance is intended to be connected to the mains electrical supply by means of an isolation switch and fused spur and is intended to be protected by a 3A fuse. The use of a 13A fuse can cause damage to the internal wiring in the event of a fault, and may also invalidate the warranty.

Electrical Information

Mains electrical voltage: 230 – 240Vac, 50Hz

Total rated power consumption:
290W

Troubleshooting

If your extractor is not working:

1. Check that the mains supply has not been switched off.
2. Check that the fuse in the spur has not blown.

DOUBLE POLE SWITCHED
FUSED SPUR OUTLET

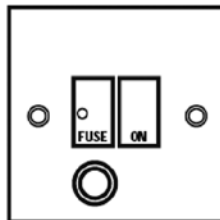

USE A 3 AMP FUSE

Installation

IMPORTANT:

The extractor is intended to be mounted directly to the ceiling using fixings appropriate for the ceiling. Ensure that there is adequate ceiling strength and supports at the fixing points; if in doubt, consult a joiner or electrician.

Your extractor can be used to filter and recycle the air within your kitchen (A), or to extract the air outside (B). When extracting air to the outside, the unit can be vented as shown in the diagram below. Note that we recommend the use of ducting with a diameter of 150mm. Ducting with diameters of 100mm or 120mm may be used, but performance will be reduced.

When installing this appliance over a CDA hob, the clearance between the extractor and the hob must be equal to or exceed 650mm. This instruction overrides the instructions supplied with the CDA hob. (The height should be measured from the top of the hotplates or burners)

Where the extractor is to be installed above a non-CDA hob, the instructions supplied with the hob may dictate that the height required above the hob is greater than 650mm.

IN THE ABSENCE OF ANY INSTRUCTIONS SUPPLIED WITH THE HOB, THE MINIMUM DISTANCE BETWEEN THE HOB AND EXTRACTOR MUST BE AT LEAST 760mm.

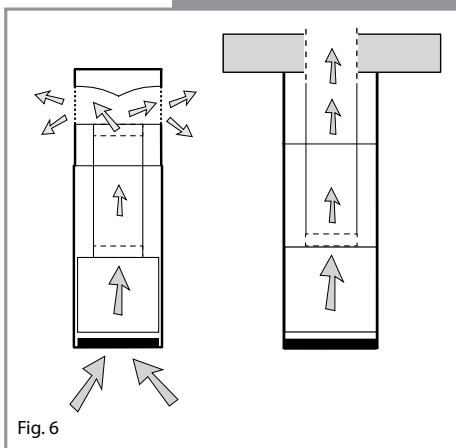

Fig. 6

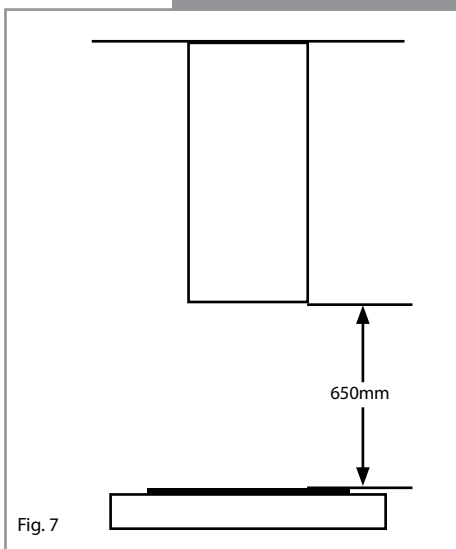
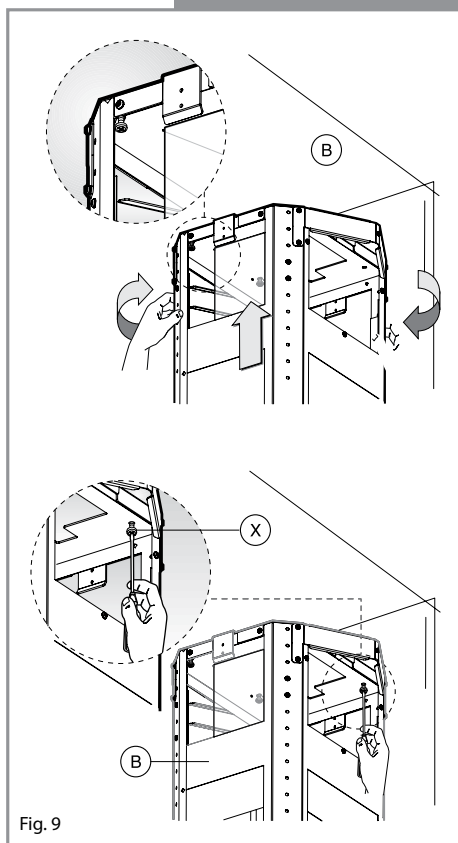
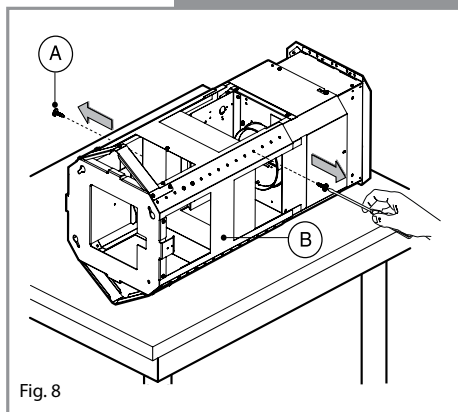

Fig. 7

Mounting your extractor

1. Using the supplied template, mark the positions of the 3 main fixing holes and the additional fixing hole (X) on the ceiling.
2. Drill and plug the holes, as required. If screwing directly to the ceiling joists, plugs may not be required (See Important note above)
3. Insert 3 screws into the main fixings, leaving approximately 3mm protruding, as shown in Fig 8.
4. Fit the upper support section (B) into position on the 3 screws and rotate it into position, as shown in Fig 9.
5. When in position, tighten the 3 main screws and fit an additional screw (X) to fix the support plate in position.



Mounting your extractor

- When using a CDA hob, the extractor is required to be 650mm above the hotplates. Measure the height of the ceiling and then the hotplate height from the floor. The length of the support sections should be calculated as follows: -

Length of support = Ceiling height - (149 + 650 + Hotplate height)

Note that if the exact height cannot be set, use the frame position corresponding to the next highest one.

- Fit the lower section (B) to the upper section (C) at the correct height and secure in position using the supplied screws (G)
- Refit (if required) and secure the motor body to the lower section and secure with the supplied screws.

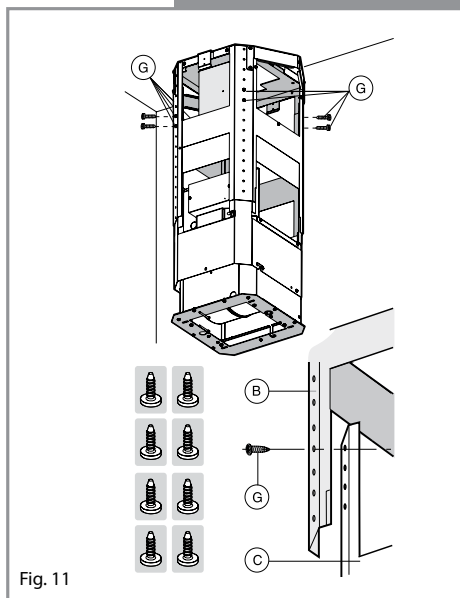
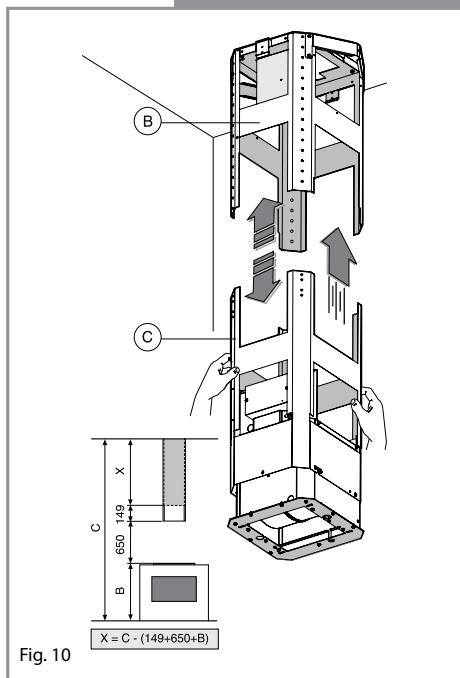

Mounting your extractor

- Assemble the ventilation duct(H), as shown in the diagrams below dependant on whether you are extracting air to the outside (Fig 12) or re-circulating (Fig 13), in which case you will need to purchase an optional accessory T-piece(M) from CDA. Ensure that the duct adapter (F) is securely connected to the duct pipe or T-piece in order to minimise noise.
- Separate the two decorative sections and mount the upper section(Y) into position, then fix it to the frame with the 2 supplied screws(X).
- Carefully slide the lower section (L) over the upper section (Y) and secure into position using the 4 machine screws (A) as shown in Fig 15.

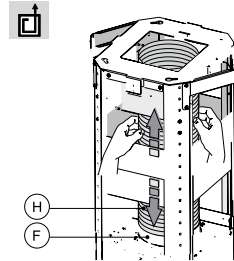

Fig. 12

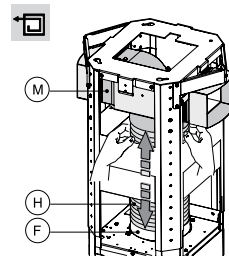

Fig. 13

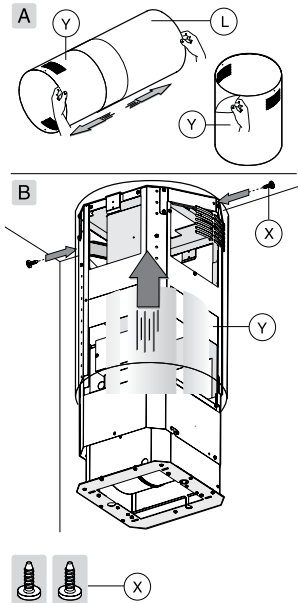

Fig. 14

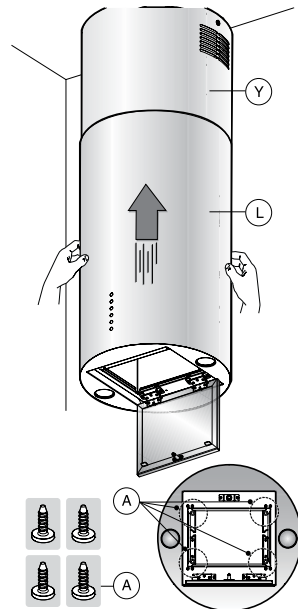

Fig. 15

Mounting your extractor

IMPORTANT NOTE:

The extractor is now mounted and secured to the wall; the electrical connections are now required to be made in order for the extractor to function.

1. Ensure that there are no trapped wires - The mains lead and control wires are easily trapped when securing the stainless section to the motor.
2. Locate the main terminal box (on the left as you look at it) and remove the 2 screws, shown as D on the diagram below. Connect the main connector plug (Shown as B in the diagram) and replace the cover.
3. Locate the control terminal box (on the right) and remove the 2 screws. Connect the connector as shown in the diagram (A) and refit the terminal cover.

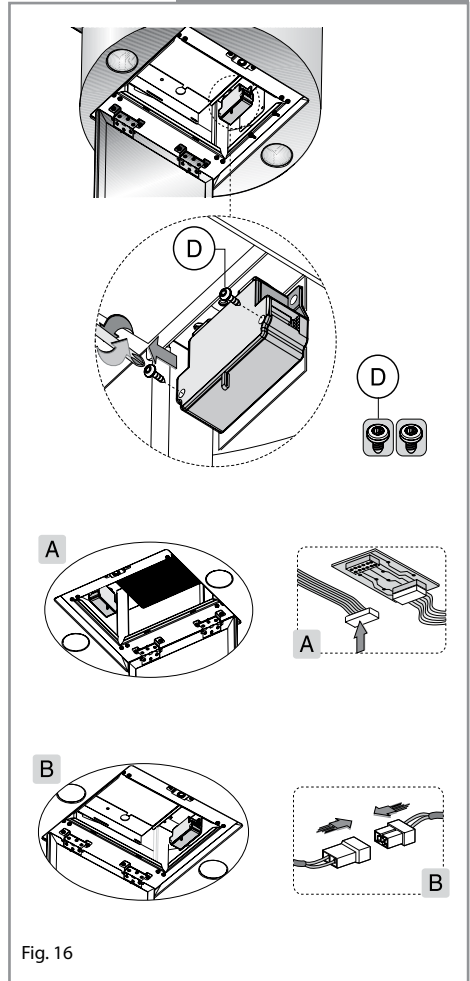



NOTES



NOTES





NOTES

Energy Efficiency Information

Attribute	Symbol	Value	Units
Model Identification		evck4	
Annual Energy Consumption	AEC_{Hood}	100.0	kWh
Time increase factor	f	1.5	
Fluid Dynamic Efficiency	FDE_{Hood}	14.7 (D)	
Energy Efficiency Index	EEl_{Hood}	91.0 (D)	
Measured airflow at Best Efficiency Point	Q_{BEP}	281.4	m^3/h
Measured Pressure at Best Efficiency Point	P_{BEP}	248.0	Pa
Maximum airflow	Q_{MAX}	503.0	m^3/h
Measured electric power at Best Efficiency Point	W_{BEP}	132.0	W
Nominal lighting power	WL	40.0	W
Average illumination of the lighting system on the cooking surface	E_{Middle}	414.0	Lux
Measured power consumption in standby	P_{S}	1.0	W
Measured power consumption off mode	P_{O}	NA	W
Sound power level	L_{WA}	62.0	dBA
Grease Filter Efficiency	GFE_{Hood}	45 (G)	%
Lamp efficiency	LE_{Hood}	10.4 (E)	%



To contact our Customer Care Department, or for Service,
please contact us on the details below.