

HVG 77 .. - 4Q5 ..
Gas on Glass Cooktops
Manual for Installation, Use and Maintenance

CDA

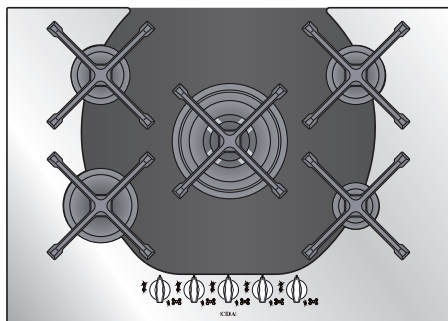
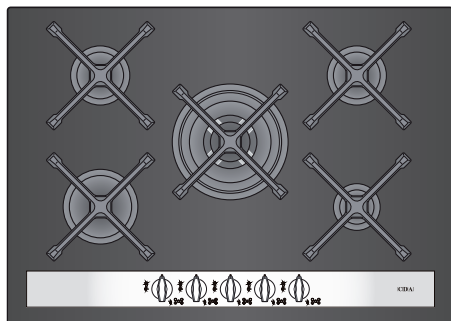

Important

This appliance is designed and manufactured solely for the cooking of domestic (household) food and is not suitable for any non domestic application and therefore should not be used in a commercial environment.

The appliance guarantee will be void if the appliance is used within a non domestic environment i.e. a semi commercial, commercial or communal environment.

These instructions are only valid for those countries whose identification symbol appears on the cover of the instruction booklet and on the appliance.

The CDA Group Ltd cannot be held responsible for injuries or losses caused by incorrect use or installation of this product. Please note that CDA reserve the right to invalidate the guarantee supplied with this product following incorrect installation or misuse of the appliance.

Appliance Information:

Please enter the details on the appliance rating plate below for reference, to assist CDA Customer Care in the event of a fault with your appliance and to register your appliance for guarantee purposes.

Appliance Model	<input type="text"/>
-----------------	----------------------

Serial Number	<input type="text"/>
---------------	----------------------

Declaration of CE Conformity

This hob (Class 3) has been designed for use only as a cooking appliance. Any other use (e.g. heating rooms) should be considered incorrect and therefore dangerous.

This hob has been designed, constructed and put on to the market in conformity with:

- Safety requirements of EU Directive "Gas" 2009/142/EC;
- Safety requirements of EU Directive "Low Voltage" 2006/95/EC;
- Protection requirements of EU Directive "EMC" 2004/108/EC;
- Requirements of EU Directive 93/68/EEC.

Important Safeguards and Recommendations

- Do not carry out any cleaning or maintenance without first disconnecting the appliance from the electrical supply.
- During and after use of the hob, certain parts will become very hot. Do not touch hot parts.
- After use always ensure that the control knobs are in the “●” (off) position.
- Young children should be supervised to ensure that they do not play with the appliance.
- Keep children away from the hob during use.
- Children, or persons with a disability which limits their ability to use the appliance, should have a responsible person to instruct them in its use. The instructor should be satisfied that they can use the appliance without danger to themselves or their surroundings.
- Do not allow young children or infirm persons to use the appliance without your supervision.
- **WARNING!** When correctly installed, your product meets all safety requirements laid down for this type of product category. However special care should be taken around the underneath of the appliance as this area is not designed or intended to be touched and may contain sharp or rough edges, that may cause injury.
- **Fire Risk!** Do not leave inflammable materials on the hob top.
- Make sure that electrical cords connecting other appliances in the proximity cannot come in to contact with the hob top.
- Never use a damaged appliance. Get it checked or repaired: “see Appliance Servicing”.
- When the appliance is not being used, it is advisable to keep the gas tap closed.
- Regular lubrication of the gas taps must only be carried out by qualified engineers. Contact Service in case of problems with the operation of the gas taps.
- Before disposing of an unwanted appliance, it is recommended that it is made inoperative and that all potentially hazardous parts are made harmless.
- **If the supply cord is damaged, it must be replaced by a special cord by a qualified electrical technician in order to avoid a hazard.**

Before Using for the First Time

- Read the instructions carefully before installing and using the appliance
- After unpacking the appliance, make sure it is not damaged. In case of doubt, do not use the appliance and contact your supplier or a qualified engineer.
- Remove all packaging and do not leave the packing material (plastic bags, polystyrene, bands etc) in easy reach of children as they may cause serious injury. The packaging materials are recyclable.
- The appliance should be installed and all the gas/electrical connections made by a qualified engineer in compliance with local regulations in force and following the manufacturer’s instructions.
- Do not attempt to modify the technical properties of the appliance, as it may become dangerous to use.

Features and Technical Data

Fig. 1a

Mod. HVG 77 ..

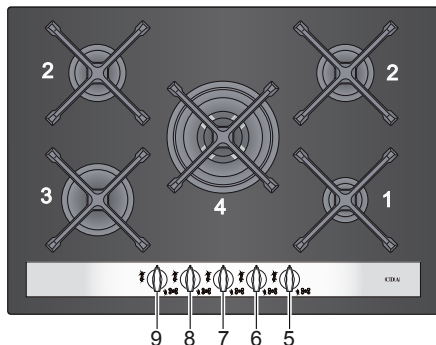
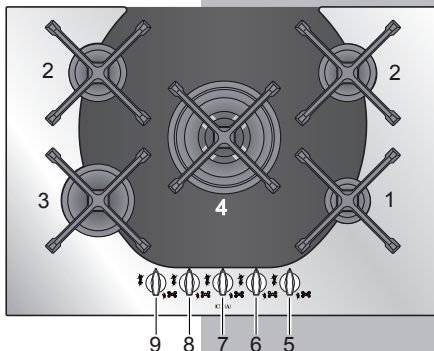

Fig. 1b

Mod. 4Q5 ..



Cooking Points

- | | | |
|----|-------------------------|---------|
| 1. | Auxiliary burner (A) | 1,00 kW |
| 2. | Semi-rapid burner (SR) | 1,75 kW |
| 3. | Rapid burner (R) | 3,00 kW |
| 4. | Triple ring burner (TR) | 3,50 kW |

Control Panel

5. Auxiliary burner control knob (1)
6. Rear right semi-rapid burner control knob (2)
7. Triple ring burner control knob (4)
8. Rear left semi-rapid burner control knob (2)
9. Rapid burner control knob (3)

Note:

- The electric ignition is incorporated in the knobs.
- The appliance has a safety valve system fitted, the flow of gas will be stopped if and when the flame should accidentally go out.

Caution:



- If the burner is accidentally extinguished, turn the gas off at the control knob and wait at least 1 minute before attempting to relight.
- Gas hobs produce heat and humidity in the environment in which they are installed. Ensure that the cooking area is well ventilated by opening the natural ventilation grilles or by installing an extractor hood connected to an outlet duct.
- If the hob is used for a prolonged time it may be necessary to provide further ventilation by opening a window or by increasing the suction power of the extractor hood (if fitted).

**This appliance is
class 3**

How to Use the Hob

Gas Burners

Gas flow to the burners is adjusted by turning the knobs (illustrated in fig. 2) which control the valves. Turning the knob so that the indicator line points to the symbols printed on the panel achieves the following functions:

- Symbol  : Tap closed (burner off)
- Symbol  : High (maximum)
- Symbol  : Low (minimum)

- The maximum aperture position permits rapid boiling of liquids, whereas the minimum aperture position allows slower warming of food or maintaining boiling conditions of liquids.
- To reduce the gas flow to minimum, rotate the knob further anti-clockwise to point the indicator towards the small flame symbol.
- Other intermediate operating adjustments can be achieved by positioning the indicator between the maximum and minimum aperture positions, and never between the maximum aperture and closed positions.

Caution!

The cooking hob becomes very hot during operation. Keep children well out of reach.

Lighting Gas Burners

In order to light the burners, you must:

- 1 - Press in the corresponding knob and turn counter-clockwise to the full flame position marked by the  symbol (fig. 3) and hold the knob in until the flame has been lit.
In the case of a mains failure light the burner with a match or lighted taper.
- 2 - Wait about ten seconds after the gas lighting before releasing the knob (starting time for the valve).
- 3 - Adjust the gas valve to the desired power.

Important:

If the burner flame should go out for some reason, the safety valve will automatically stop the gas flow. To re-light the burner, return the knob to the closed "●" position, wait for at **least 1 minute** and then repeat the lighting procedure.

If your local gas supply makes it difficult to light the burner with the knob set to maximum, set the knob to minimum and repeat the operation.

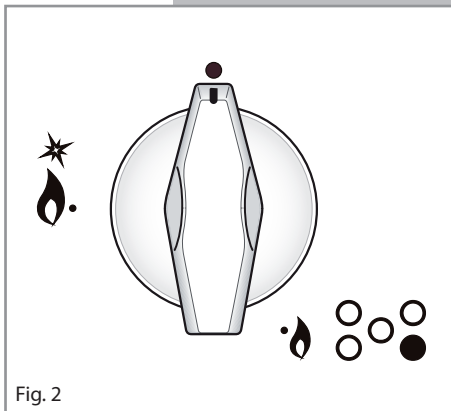

Fig. 2

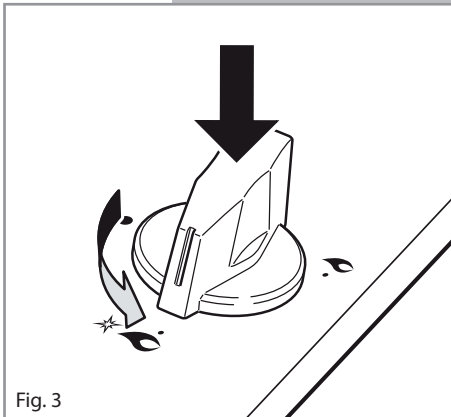

Fig. 3

Choice of Burner

The symbols printed on the panel by the side of the knob indicate which burner you are controlling.

Choose a suitable burner depending on the cookware diameter and capacity.

The pan diameter should be suitable for the burner power to make the most of the burner's high efficiency and not waste fuel.

A small pan does not boil more quickly on a large burner (fig. 4).

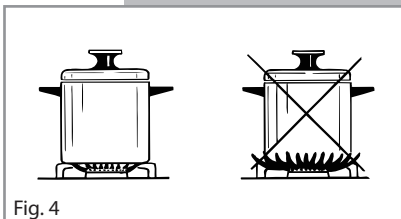

Fig. 4

Burner Size	Minimum Pan Diameter (cm)	Maximum Pan Diameter (cm)
Auxiliary	12	14
Semi-Rapid	16	24 (1)
Rapid	24	26
Triple Ring	26	28
Wok (2)	-	36

do not use pans with concave or convex bases

1) Front right burner, maximum diameter 20 cm.
 (2) Wok pans have to be used only with the special grille fitted (see correct use of triple-ring burner).

Correct Use of Triple-Ring Burner

- The flat-bottomed pans are to be placed directly onto the pan-support.
- To use the WOK you need to place the proper stand in order to avoid any faulty operation of the triple-ring burner (Figs. 5a - 5b).

IMPORTANT: The wok pan stand (fig. 5b) **MUST BE PLACED ONLY** over the pan-rest for the triple ring burner.

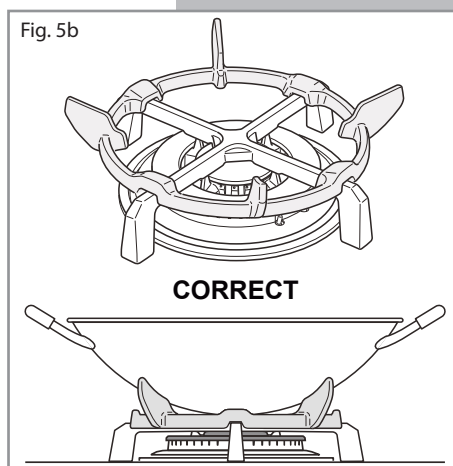
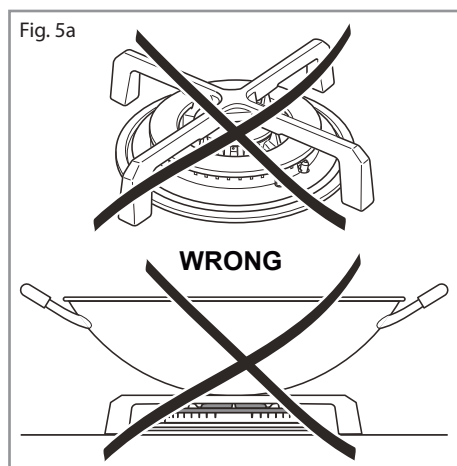

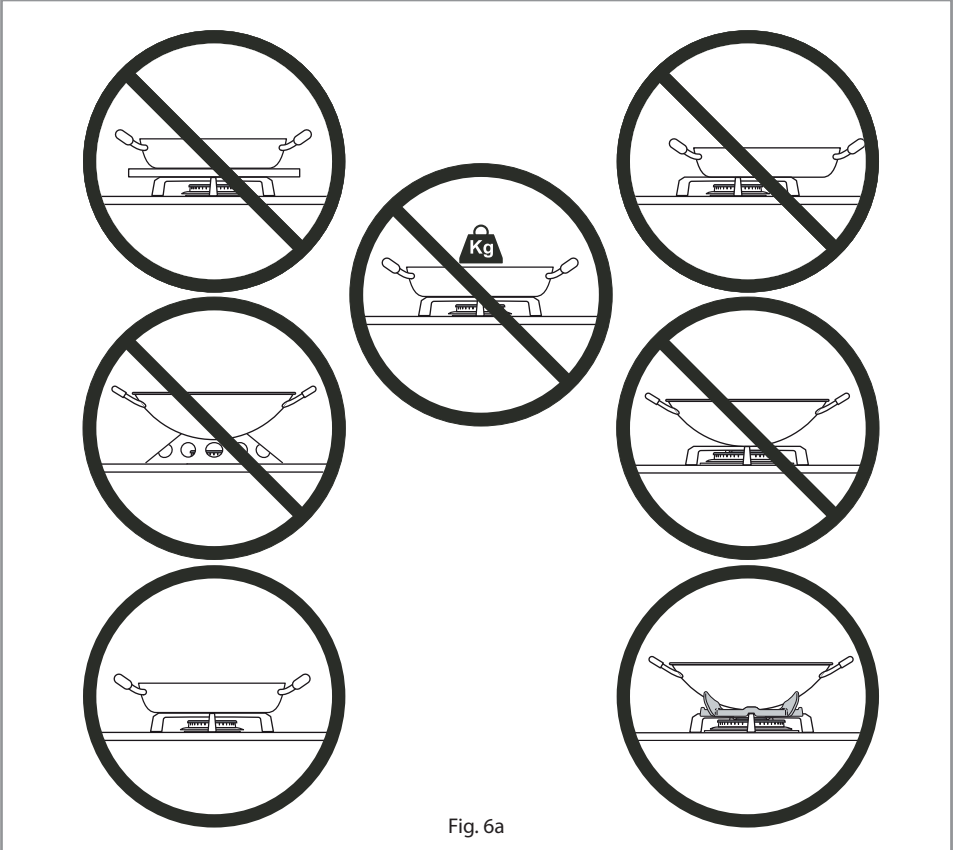

Fig. 6a

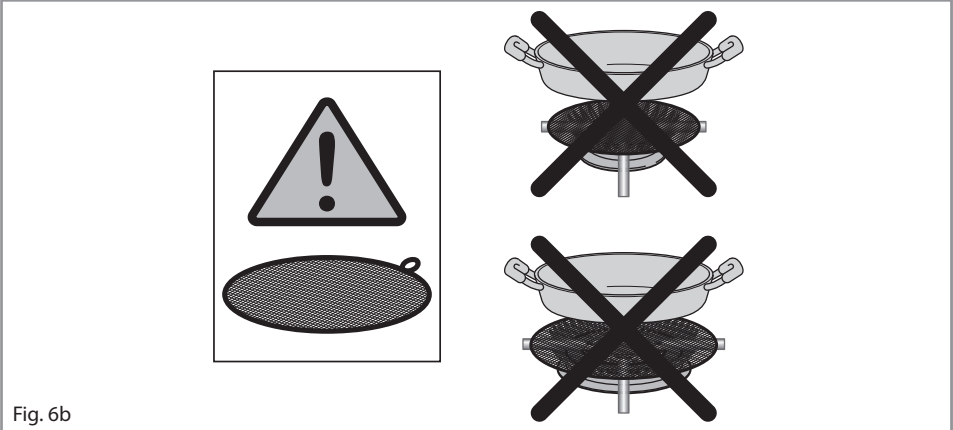

Fig. 6b

Cleaning and Maintenance

General Tips

- Before cleaning the hob switch it off and wait for it to cool down.
- Clean with a cloth, hot water and soap or liquid detergent.
- Do not use products which are abrasive, corrosive or chlorine based.
- Do not use steel pads.
- Avoid using cleaning products with a chlorine or acidic base.
- Do not leave acid or alkaline substances (vinegar, salt, lemon juice, etc.) on the hob.
- **Steam cleaners must not be used when cleaning this appliance.**
- **WARNING:** When correctly installed, your product meets all safety requirements laid down for this type of product category. However special care should be taken around the underneath of the appliance as this area is not designed or intended to be touched and may contain sharp or rough edges, that may cause injury.

Glass Surface

- Remove spillages and other types of incrustations by using only specific products which do not contain abrasives or chlorine-based acids.
- If you use a detergent, please make sure that it is not abrasive or scouring. Abrasive or scouring powders can damage the glass surface of the hob.
- All traces of the cleaner must be removed with a damp cloth.
- Dust or food particles can be removed with a damp cloth.
- Dust, fat and liquids from food that has boiled over must be removed as soon as possible.
- If they are allowed to harden they become increasingly difficult to remove. This is especially true in the case of sugar/syrup mixtures which could permanently damage the surface of the hob if left to burn on it.
- Avoid using a knife or other sharp utensil as these may damage the glass surface.
- Do not use steel wool or an abrasive sponge which could scratch the surface permanently.
- Do not put articles on the hob which can melt: i.e plastic, aluminium foil, sugar, sugar syrup mixtures etc.

Enamelled Parts

- All the enamelled parts must be washed only with a sponge with soapy water or other non-abrasive products.
- Dry preferably with a soft cloth. If acid substances such as lemon juice, tomato conserve, vinegar etc. are left on the enamel for a long time they will etch it, making it opaque.

Stainless Steel Surfaces (Some Models Only)

- Stainless steel parts should be rinsed with water and dried with a microfibre or soft cloth.
- For persistent dirt, use specific non-abrasive products available commercially or a little hot vinegar.
- Note: regular use will cause discolouring around the burners, because of the high flame temperature.

Gas Taps

- Regular lubrication of the gas taps must only be performed by specialised engineers.
- If the gas taps are not working properly call the After-Sales Service.

Control Knobs

- The control knobs may be removed for cleaning but care should be taken not to damage the seal.

CAUTION:

Do not use harsh abrasive cleaners or sharp metal scrapers to clean the glass since they can scratch the surface, which may result in shattering of the glass.

Burners and Grids

- These parts can be removed and cleaned with appropriate products.
- After cleaning, the burners and their flame spreaders must be well dried and correctly replaced.
- It is very important to check that the burner flame spreader and the cap have been correctly positioned. Failure to do so can cause serious problems.
- Check that the electrode "S" (figs. 8 and 11) is always clean to ensure trouble-free sparking.
- Check that the probe "T" (figs. 8 and 11) next to each burner is always clean to ensure correct operation of the safety valves.
- **Both the probe and ignition plug must be very carefully cleaned.**
- **Note: To avoid damage to the electric ignition do not use it when the burners are not in place.**

IMPORTANT WARNING

NEVER unscrew the burner plate fixing screws (fig. 7).

The burner plates can be removed **ONLY** by an authorised service agent.

Damage to the appliance will occur if not observing this condition and this may result in serious injury to the user.

The manufacturer declines every responsibility for any inconvenience resulting from the inobservance of this condition.

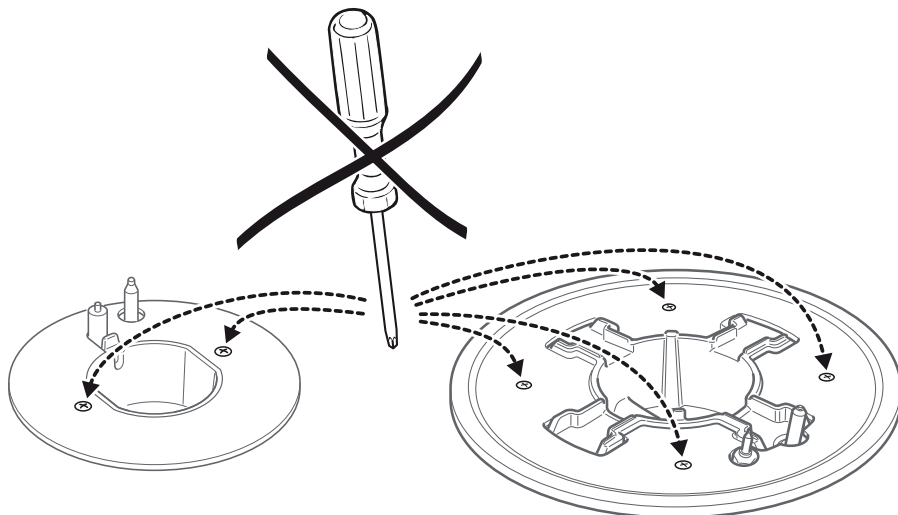
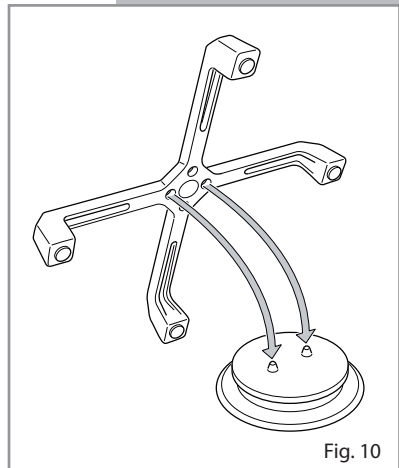
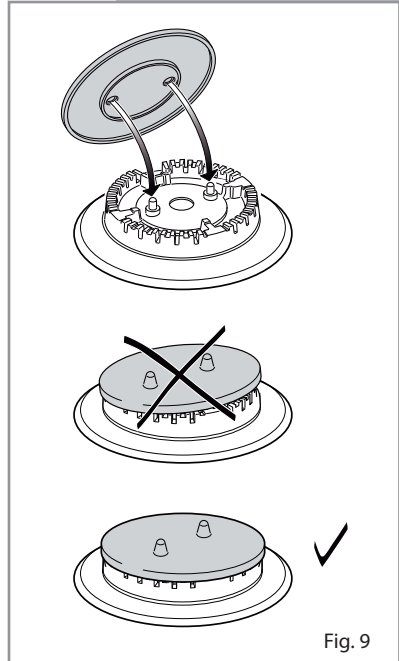
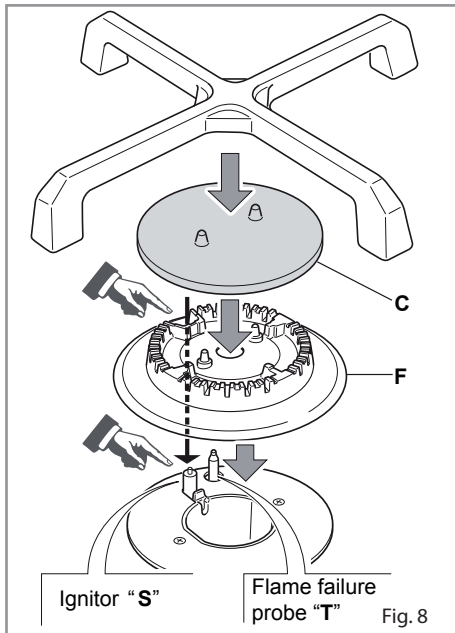

Fig. 7

Correct Positioning of the Auxiliary, Semi-rapid and Rapid Burners

- It is very important to check that the burner flame spreader "F" and the cap "C" have been correctly positioned (see figs. 8 and 9). They shall be level and must not rotate. Failure to do so can cause serious problems.
- The pan supports shall be correctly positioned as indicated in fig. 10. The pan supports shall be level and must not rotate.
Be sure not to fit the triple-ring burner pan support on the auxiliary, semirapid or rapid burners. The triple-ring burner pan support IS ONLY to be used on the triple-ring burner.



Correct Positioning of the Triple Ring Burner

- The triple ring burner must be correctly positioned (see fig. 11); the burner ribs must be fitted in their housing as shown by the arrow. The burner correctly positioned must not rotate (fig. 12).
 - Then position the cap "A" and the ring "B" (figs. 12 and 13). They shall be level.
 - The pan support shall be correctly positioned as indicated in fig. 14. The pan support shall be level and must not rotate.
- Be sure not to fit the auxiliary, semirapid or rapid burner pan support on the triple-ring burner. The auxiliary, semirapid or rapid burner pan support IS ONLY to be used on the auxiliary, semirapid or rapid burners.

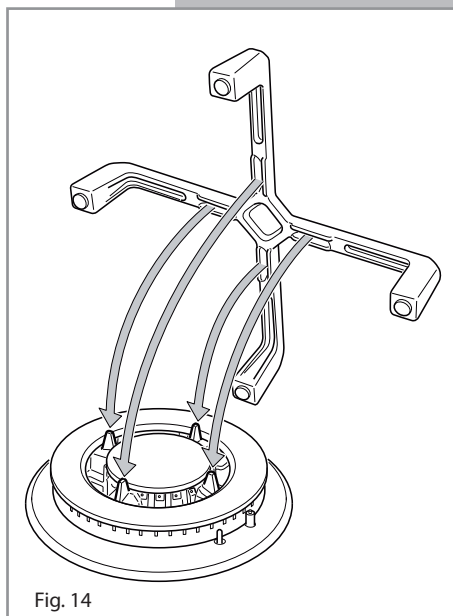
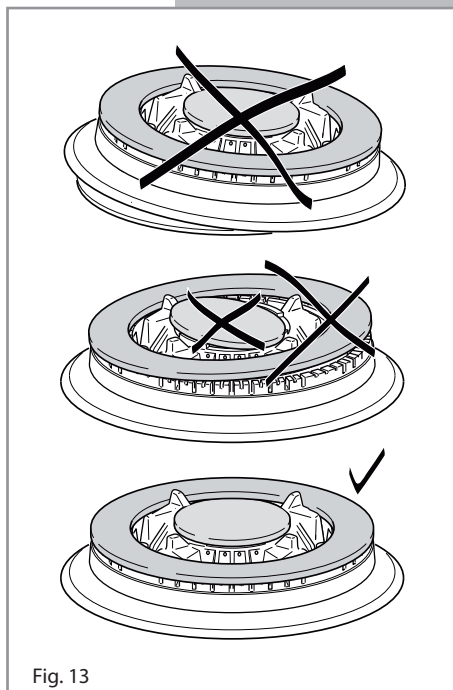
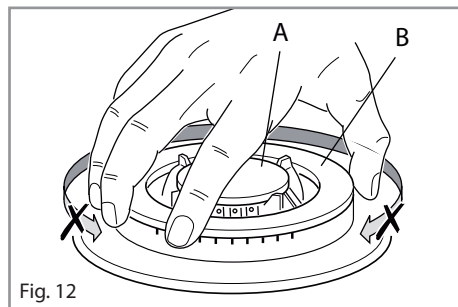
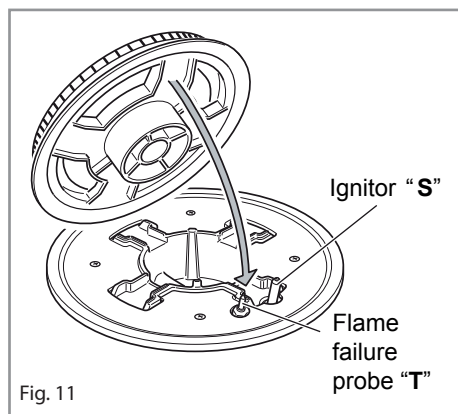

TIPS FOR INSTALLATION

Location

- The appliance may be installed in a kitchen, Kitchen/diner or a bed sitting room, but not in a room or space containing a bath or a shower.
- The appliance must not be installed in a bed-sitting room of less than 20m³.
- The appliance is designed and approved for domestic use only and should not be installed in a commercial, semi commercial or communal environment.
- Your product will not be guaranteed if installed in any of the above environments and could affect any third party or public liability insurances you may have.
- This hob should only be installed by a qualified installer. Failure to observe this rule leads to cancellation of the guarantee.
- The appliance must be installed correctly, in compliance with the regulations in force and following the manufacturer's instructions.
- Any repair or maintenance must be performed with the appliance switched off.
- These hobs are designed to be fitted into 600 mm deep kitchen units.
- These appliances have been designed and manufactured to be fitted into heat-resistant units.
- The unit walls must not be higher than the working surface and must withstand a temperature of 105°C above room temperature.
- We would point out that the adhesive which bonds the plastic laminate to the furniture must withstand temperatures not less than 150 °C to avoid delamination.
- Avoid installation near inflammable materials (e.g. curtains).

Provision for Ventilation

- The appliance should be installed into a room or space with an air supply in accordance with BS 5440-2: 2000.
- For rooms with a volume of less than 5m³ - permanent ventilation of 100cm² free area will be required.
- For rooms with a volume of between 5m³ and 10m³ a permanent ventilation of 50cm² free area will be required unless the room has a door which opens directly to the outside air in which case no permanent ventilation is required.
- For rooms with a volume greater than 10m³ - no permanent ventilation is required.

Note: Regardless of room size, all rooms containing the appliance must have direct access to the outside air via an openable window or equivalent.

- Where there are other fuel burning appliances in the same room, BS 5440-2: 2000 should be consulted to determine the correct amount of free area ventilation requirements.
- The above requirements allow also for use of a gas oven and grill but if there are other gas burning appliances in the same room, consult a qualified engineer.

Installation

Technical Information For The Installer

In order to install the cooktop into the kitchen fixture, a hole with the dimensions shown in fig. 16 has to be made, bearing in mind the following:

- Within the unit, between the bottom of the cooktop and the upper surface of a shelf there must be a clearance of at least 30mm. It is absolutely essential that you place a separator between the base of the cooktop and the built-in unit or the oven;
- The cooktop must be kept no less than 260mm away from any side wall (between the side of the cut-out and the side wall - fig. 15).
- There must be a distance of at least 60mm between the back side of the cut-out and the back of the countertop (fig. 16).
- There must be a distance of at least 650mm between the hob and any wall cupboard or extractor hood positioned immediately above (see fig. 15).
- There must be a distance of at least 650mm between the hob and any wall cupboard or extractor hood positioned immediately above (see fig. 15).
- If the hob is installed over a built-in oven, the built-in oven shall be provided with cooling fan. The two appliances shall be connected to the gas/electric supply with independent connections.

Fig. 15

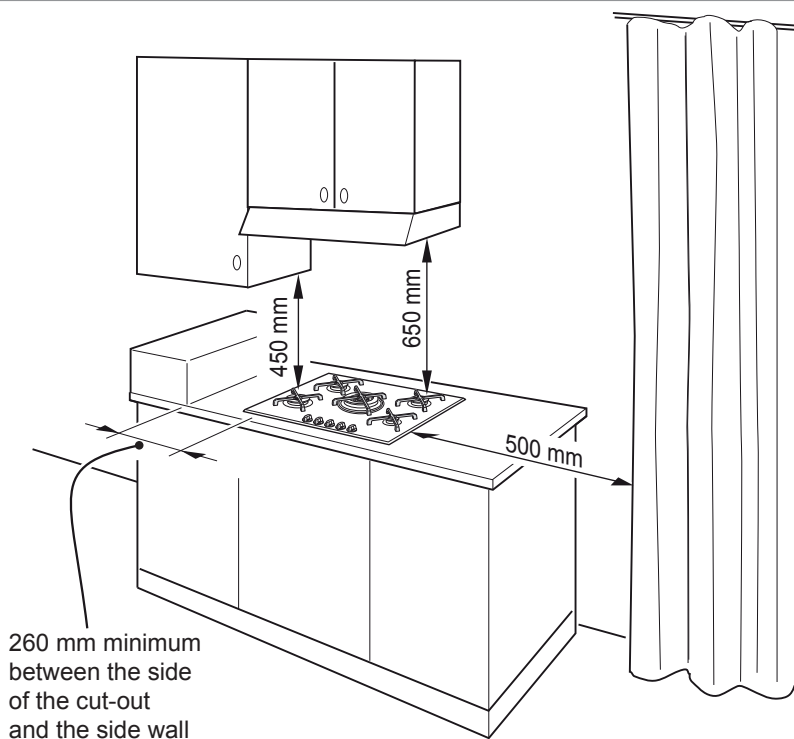
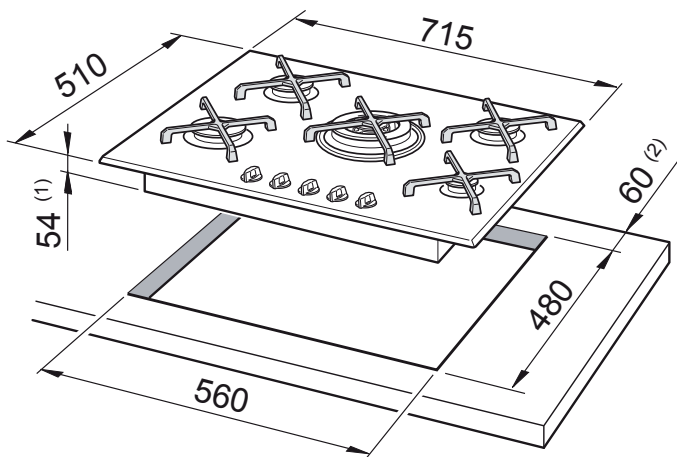

Fig.16



- (1) 54mm from top of countertop
- (2) at least 60mm between the back side of the cut-out and the back of the countertop.

Installing the Separator Below the Base of the Cooktop

It is recommended that a 30mm clearance be left between to base of the cooktop and the separator. The separator shall be heat resistant, made of low thermal conductivity material and shall be removable with the use of a tool for installation and service.

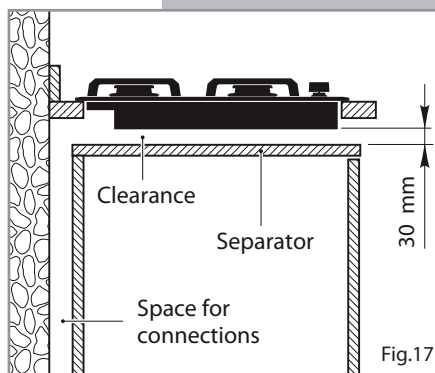
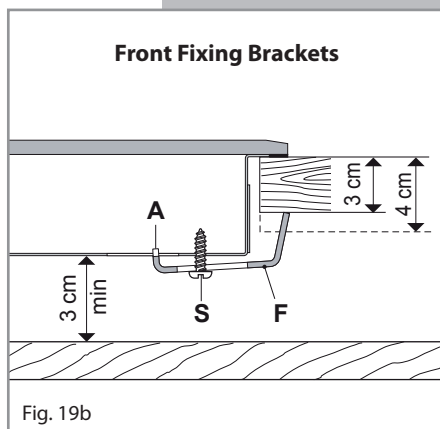
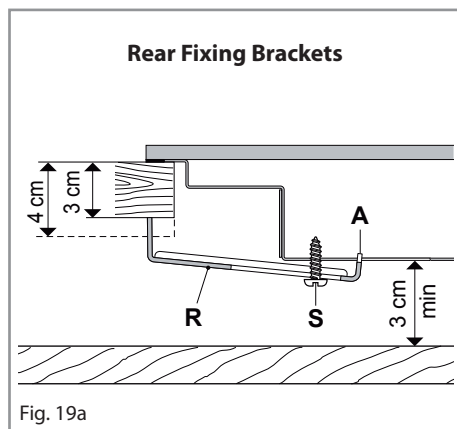
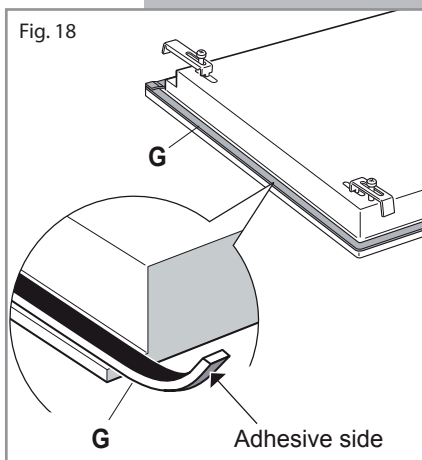

Fig.17

Fastening the Cooktop

Each cooktop is provided with an installation kit including brackets and screws for fastening the cooktop to benches from 30 to 40mm thick. The kit includes two "F" type brackets (for the front of the cooktop), two "R" type brackets (for the rear of the cooktop) and four self-threading screws "S" (figs. 19a and 19b).

- Cut the unit according to the dimensions in fig. 16.
- Turn the hob upside down and rest the glass side on a soft surface.
- Spread the seal "G" around the edge of the hob (fig. 18).
- Fasten the brackets "F" and "R" to the appropriate socket holes, without tightening the screws "S" for the moment. Make sure that the tabs are mounted correctly, as shown. Rotate the tabs so that the cooktop can be put into the cutout.
- Put the cooktop into the cutout and position it correctly.
- Put the brackets "F" and "R" into place; tooth "A" of the brackets should go into the hole (Figs. 19a and 19b).
- Tighten screws "S" until the cooktop is completely secured to the bench.
- Using a sharp cutter or trimmer knife, trim the excess sealing material around the edge of the cooktop. Take care not to damage the workbench.



Gas Supply Requirements

Important Note

This appliance is supplied for use on NATURAL GAS or LPG (check the gas regulation label attached on the appliance).

- Appliances supplied for use on NATURAL GAS: they are adjusted for this gas only and cannot be used on any other gas (LPG) without modification. The appliances are manufactured for conversion to LPG.
- Appliances supplied for use on LPG: they are adjusted for this gas only and cannot be used on any other gas (NATURAL GAS) without modification. The appliances are manufactured for conversion to NATURAL GAS.

If the NATURAL GAS/LPG conversion kit is not supplied with the appliance this kit can be purchased by contacting the After-Sales Service.

Installation and Service Regulations (United Kingdom Only)

This appliance must be installed and serviced only by a suitably qualified and registered person, and in accordance with the current editions of the following standards and regulations or other locally applicable regulations:

- Gas Safety (Installation and Use) Regulations
- Building Regulations
- British Standards
- Regulations for Electrical Installation

Installation and service of any gas product must be made by a suitably qualified and registered person competent on the type of product being installed or serviced and holding a valid certificate of competence for the work being carried out. Currently the proof of competence is the Accredited Certification Scheme (ACS) or S/NVQ that has been aligned to the ACS.

It is also a requirement that all businesses or self employed installers are members of a class of person approved by the Health and Safety Executive.

Failure to install the appliance correctly could invalidate any manufacturers warranty and lead to prosecution under the above quoted regulation.

Gas Connection

The installation of the gas appliance to Natural Gas or LP Gas must be carried out by a **suitably qualified and registered installer**. Installers shall take due account of the provisions of the relevant British Standards Code of Practice, the Gas Safety Regulations and the Building Standards (Scotland) (Consolidation) Regulations issued by the Scottish Development Department.

Installation to Natural Gas

Installation to Natural Gas must conform to the Code of Practice, etc.

The supply pressure for Natural Gas is 20 mbar.

The installation must conform to the relevant British Standards.

Installation to LP Gas

When operating on Butane gas a supply pressure of 28-30 mbar is required.

When using Propane gas a supply pressure of 37 mbar is required.

The installation must conform to the relevant British Standards.

CDA are not legally able to provide any assistance in the installation of gas appliances except to suitably qualified and registered installers. Any suitably qualified and registered fitter requiring help must provide name, address and registration number.

Information supplied will be validated before help is provided.

Warning:

Only a suitably qualified and registered installer, also with technical knowledge of electricity should install the appliance. He should observe the Regulations and Codes of Practice governing such installation of gas appliances.

Note: It is recommended that the gas connection to the appliance is installed with a flexible connecting tube made to BS5386.

Notes:

- **Flexible hoses can be used where the sited ambient temperature of the hose does not exceed 70°C. These hoses must be manufactured in accordance with BS669 part 1 and be of the correct construction for the type of gas being used.**
- **Gas hoses designed for natural gas MUST NOT be used for supplying LPG gas (LPG gas hoses can be identified by a either a red band or stripe on the rubber outer coating of the hose). The hose should not be crushed or trapped or be in contact with sharp or abrasive edges.**

Gas Connection **GB** Cat: II 2H3+

The fitting (fig. 20) is made up of:

- 1 nut "A"
- 1 elbow fitting "C"
- gasket "F"

Connection to the Gas Supply

- Be careful when flexible pipes are used that they do not come into contact with moving parts.
- To maintain the thickness of 3 cm, the hob is fitted with a channel to contain the connection pipe.
- The gas inlet union can be turned in the direction required after the elbow fitting "C" and nut "A" connection (figure 20) has been slackened (Fig. 21).
- Never put it in the horizontal or vertical position.
- Never attempt to turn the elbow "C" without having first slackened off the relative lock nut "A".
- The gasket "F" (fig. 20) guarantees the seal of the gas connection. It is recommended that it be replaced whenever it shows even the slightest deformation or imperfection.
- **Using a suitable leak detection fluid solution (e.g. Rocol) check each gas connection one at a time by brushing the solution over the connection. The presence of bubbles will indicate a leak. If there is a leak, tighten the fitting and then recheck for leaks.**
IMPORTANT! Do not use a naked flame to test for leaks.

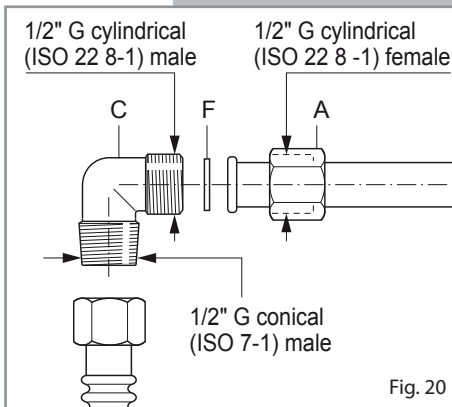

Fig. 20

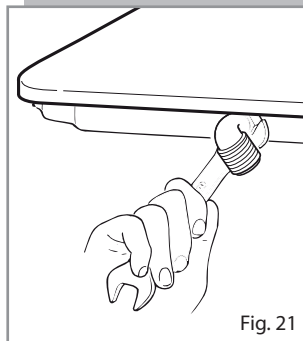

Fig. 21

If installation is to be carried out using a flexible connector (to BS669), then the following points must be adhered to:

Note: The gas installation pipes and the final connection to the appliance connecting pipe shall be sufficient size to maintain the heat output of the appliance as specified under installation.

1. The appliance flexible connector should not be subject to undue forces, either in normal use whilst being connected or disconnected.
2. The appliance flexible connector should not be subject to excessive heat by direct exposure to flue products or by contact with hot surfaces.
3. The socket into which the plug of the appliance flexible connector fits should be permanently attached to a firmly fixed gas installation pipe and positioned such that the hose hangs freely downwards.
4. The appliance flexible connector should be positioned such that it will not suffer mechanical damage; eg abrasion from the surrounding kitchen furniture which may be moved in use, such as a door or drawer, or by being trapped by a stability device.
5. The plug-in connector should be accessible for disconnection after moving the appliance.

Conversion to Natural Gas or to LPG

Replacing the Burner Injectors

If the NATURAL GAS/LPG conversion kit is not supplied with the appliance this kit can be purchased by contacting the After-Sales Service.

Choose the injectors to be replaced according to the "Table for the Choice of the Injectors". The injector diameter, expressed in hundredths of a millimetre, is marked on the injector body.

To replace the injectors proceed as follows:

- Remove the pan supports, the burner caps and flame spreaders.
- Using a wrench, substitute the nozzle injectors "J" (Figs. 22 - 23) with those most suitable for the kind of gas for which it is to be used.

The burners are made in such a way so as not to require regulation of the primary air.

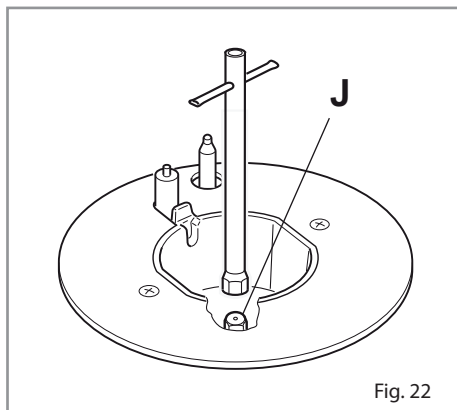

Fig. 22

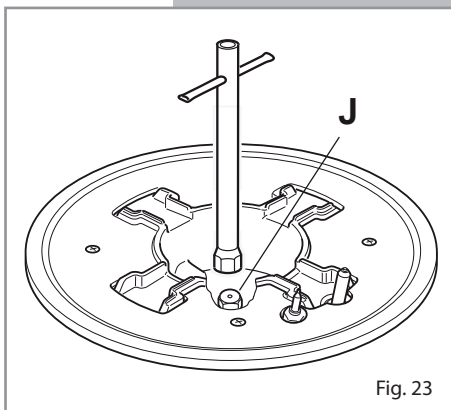

Fig. 23

Regulating the Burner Minimum Setting

When changing from one type of gas to another, the minimum tap output must also be correct, considering that in this position the flame must be about 4 mm long and must remain lit even when the knob is turned sharply from the maximum to the minimum position.

The adjustment is performed with the burner lit, as follows:

- Turn the knob to the minimum position.
- Remove the tap knob.
- Turn the screw "A" to the correct setting with a screwdriver (fig. 24).

For LPG, tighten the adjustment screw completely.

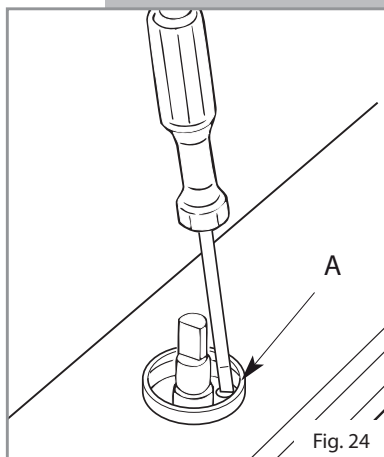



Fig. 24

Table for the Choice of the Injectors			 Cat: II 2H3+	
Burners	Nominal Power kW	Reduced Power kW	G30 - 28-30 mbar G31 - 37 mbar	G20 - 20 mbar
			Ø Injector 1/100 mm	Ø Injector 1/100 mm
Auxiliary (A)	1,00	0,30	50	72 (X)
Semi-Rapid (SR)	1,75	0,45	65	97 (Z)
Rapid (R)	3,00	0,75	85	115 (Y)
Triple Ring (TR)	3,50	1,50	95	135 (T)

Lubrication of the Gas Taps

The operations must be executed by a qualified technician.

IMPORTANT: All intervention regarding installation maintenance and conversion of the appliance must be fulfilled with original factory parts.

The manufacturer declines any liability resulting from the non-compliance of this obligation.

Mains Electricity Connection

Incorrect installation may be dangerous and the manufacturer can not be held responsible.

Warning! This appliance must be earthed. The manufacturer declines all responsibility for any problem caused by failure to observe this rule.

THIS APPLIANCE MUST BE CONNECTED TO THE MAINS SUPPLY BY A COMPETENT PERSON, USING FIXED WIRING VIA A DOUBLE POLE SWITCHED FUSE SPUR OUTLET AND PROTECTED BY A 3A FUSE.

We recommend that the appliance is connected by a qualified electrician, who is a member of the N.I.C.E.I.C. and who will comply with the I.E.E. and local regulations.

The wires in the mains lead of this appliance are coloured in accordance with the following code:

Green & Yellow = Earth, Blue = Neutral, Brown = Live.

As the colours of the wires in the mains lead for the appliance may not correspond with the coloured markings identifying the terminals connecting to the fuse spur, proceed as follows:

- The wire which is coloured green and yellow must be connected to the terminal marked E (Earth) or coloured green.
- The wire which is coloured blue must be connected to the terminal marked N (Neutral), or coloured black.
- The wire which is coloured brown must be connected to the terminal marked L (Live), or coloured red.

Note: Use a 3A Fuse

Assembly and electrical connection should be carried out by specialised personnel.

When installing this product we recommend you seek the help of another individual.

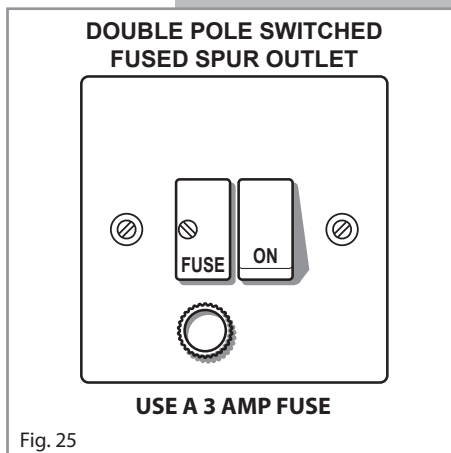

Fig. 25

Appliance Servicing

CDA provide a quality and effective after-sales service to cover all your servicing needs.

Please attach your receipt to this page for safekeeping.

Please help us to help you by having the following information available when booking a service-call:

1. Model type, make and model – see the product data plate.
2. Evidence of installation / purchase date.
3. Retailer where appliance was purchased.
4. Clear and concise details of the fault.
5. Full address including postcode and any contact phone numbers.

Contact Telephone Numbers

CDA Customer Care Department

- Telephone: 01949 862012
- Fax: 01949 862003
- Email: service@cda.eu

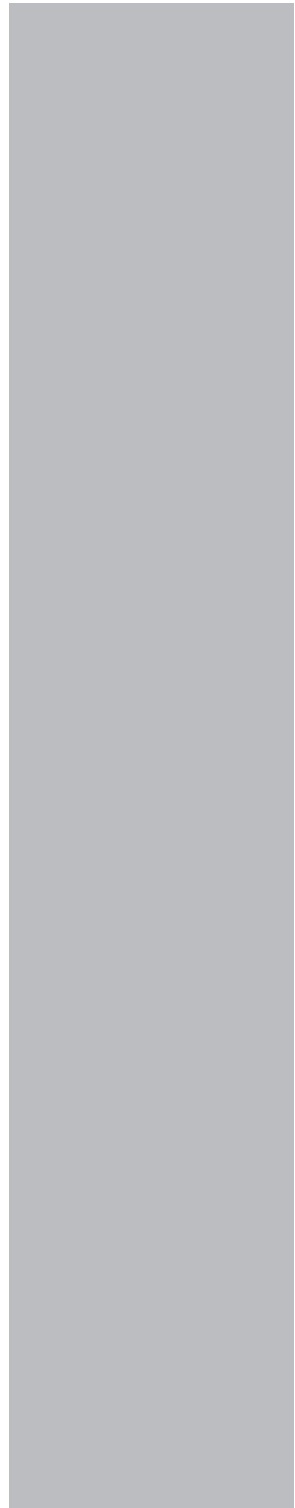

|C|D|A|

To contact our Customer Care Department, or for Service,
please contact us on the details below.