

FW882

Integrated freezer

Installation, use and maintenance

Contents

- 3 Important information
- 5 Important notes
- 5 Before first use
- 6 Important notes on use of the freezer
- 8 Storage
- 9 Control panel
- 10 Care and cleaning
- 11 Defrosting the freezer
- 11 Climate range
- 12 Troubleshooting
- 14 Installation preparation
- 14 Ventilation requirements
- 16 Installation into the cabinet
- 17 Mounting the fascia door
- 19 Reversing the appliance door
- 20 Electrical information
- 22 Warranty and service

Important

The manufacturer cannot be held responsible for injuries or losses caused by incorrect use or installation of this product. Please note that we reserve the right to invalidate the guarantee supplied with this product following incorrect installation or misuse of the appliance.

This appliance is not designed to be used by people (including children) with reduced physical, sensorial or mental capacity, or who lack experience or knowledge about it, unless they have had supervision or instructions on how to use the appliance by someone who is responsible for their safety.

Under no circumstances should any external covers be removed for servicing or maintenance except by suitably qualified personnel.

Appliance information:

Please enter the details on the appliance rating plate below for reference, to assist CDA Customer Care in the event of a fault with your appliance and to register your appliance for guarantee purposes.

Appliance Model	
-----------------	--

Serial Number	
---------------	--

EU Declarations of Conformity:

This appliance has been designed, constructed and marketed in compliance with safety requirements of EU Directive 2014/35/EU (Low voltage) and requirements of EU Directive 2014/30/EU (EMC).

This appliance has been manufactured to the strictest standards and complies with all applicable legislation, including Electrical safety (LVD) and Electromagnetic interference compatibility (EMC). Parts intended to come into contact with food conform to 1935/2004/EC.

This refrigeration appliance is intended for use as a built-in appliance.

IMPORTANT INFORMATION FOR CORRECT DISPOSAL OF THE PRODUCT IN ACCORDANCE WITH EC DIRECTIVE 2012/19/EU.

At the end of its working life, the product must not be disposed of as urban waste. The refrigeration system contains insulating gases and refrigerants, which require specialised waste disposal. The valuable materials contained in this appliance can be recycle. It must be taken to a special local authority differentiated waste collection centre or to a dealer providing this service.

Before disposing of an old appliance, remove the door seals etc. to reduce the risk of child entrapment.

Disposing of a household appliance separately avoids possible negative consequences for the environment and health deriving from inappropriate disposal and enables the constituent materials to be recovered to obtain significant savings in energy and resources. As a reminder of the need to dispose of household appliances separately, the product is marked with a crossed-out wheeled dustbin. 

Important

- Never store inflammable or explosive items and strong corrosive acids or alkalis in the appliance.
- This is a household appliance, which is produced in accordance with the national standard. It is intended for food storage only, not for storage of blood, medicine and biological products.
- To prevent risk of fire, keep the appliance away from petrol or any other inflammables.
- To prevent risk of electromagnetic interference or other accidents, do not place a microwave oven on top of the refrigerator or use any electric appliance inside the freezer.
- Do not allow children to play with or near the appliance.
- The internal surface of freezer compartment is very cold when the appliance is running. Do not touch the surface especially when hands are wet.
- Do not splash water onto the appliance. Keep it away from places of high humidity that may have adverse effect on the electric insulation performance.
- This appliance is designed to be used in ambient temperatures between 10 and 32°C. Use outside of this range may cause the appliance to fail.

Before first use

You must allow the freezer to settle for at least twenty four hours prior to switching the power on.

It is recommended that you clean the interior of the appliance prior to first use, using a solution of bicarbonate of soda and warm water and then thoroughly drying the interior.

The freezer may have an odour to it at first use. This will disappear as the appliance cools.

Please note:

The appliance will start on temperature setting 3 and work continuously until it comes down to the correct temperature. If the appliance is switched off, you should allow five minutes before switching it on again to prevent unnecessary damage to the compressor.

Never store inflammable or explosive items and strong corrosive acids or alkalis in the appliance.

This freezer cools your food by making the inside back of the cavity cold. It is normal for frost to build up on this surface; it then dissipates and drains through a small drain at the bottom, where it evaporates harmlessly. The presence of some frosting is not a malfunction of the freezer.

Freezer use

- The freezer compartments are designed to store only frozen food.
- Never put hot or warm foods in the freezer, allow them to cool fully before putting them into the freezer.
- Follow the instructions on the food packaging for storage of frozen food. If no information is provided, foods should not be stored for more than three months after the purchase date.
- Store food in small packages (ideally less than 2.5kg). This reduces the freezing time and improves the quality of the food after thawing.
- Wrap food before putting into the freezer. To stop the wrapping sticking together, ensure it is dry.
- Label the food before freezing with information including type of food and dates of storage and expiry.
- Once food is thawed, it must not be refrozen unless it has been completely cooked. Only defrost as much food as is required to prevent wastage.
- Bottled or canned drinks should not be stored in the freezer compartment as they could explode.
- Check the rating plate to confirm the maximum amount of fresh food that can be frozen within a 24 hour period.

Note: If the appliance does not have a freezer compartment () it is not suitable for freezing foodstuffs

Do not attempt to freeze more than the maximum amount.

Storage

The freezer is for short-mid term food storage. Although low temperatures can be maintained, extended periods of food storage is not recommended.

As the cold air circulates within the freezer, the temperature can vary between the different sections. As such, foods should be stored in different sections according to type and storage term. The bottom sections are the coldest parts of the freezer.

The top two sections have raisable flaps that stay open for ease of loading and unloading. The remaining 5 sections are drawers.

The 6th setting on the control panel, represented by the snowflake (Fig. 2), is a super freeze function. This should be used when freezing large quantities of food all at once. Activate this function 2 or 3 hours before introducing the food and do not leave it to run for more than necessary. Leaving it to run for longer will place unnecessary strain on the cooling system. The function will automatically deactivate after approximately 24 hours.

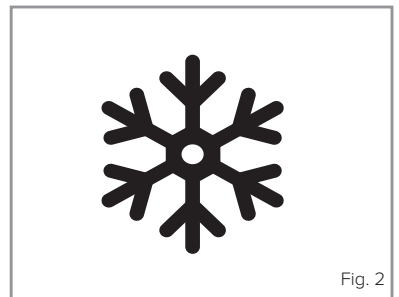
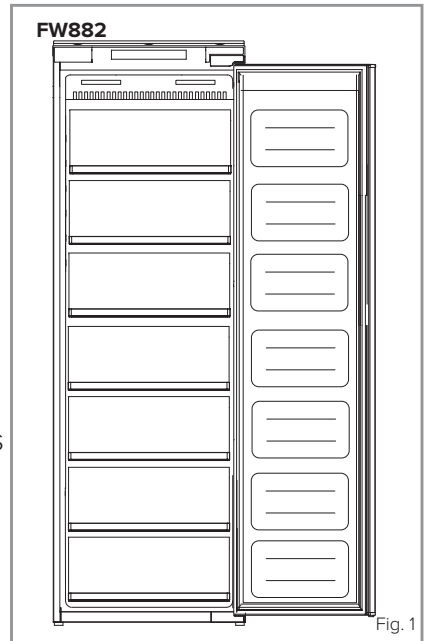

Control panel

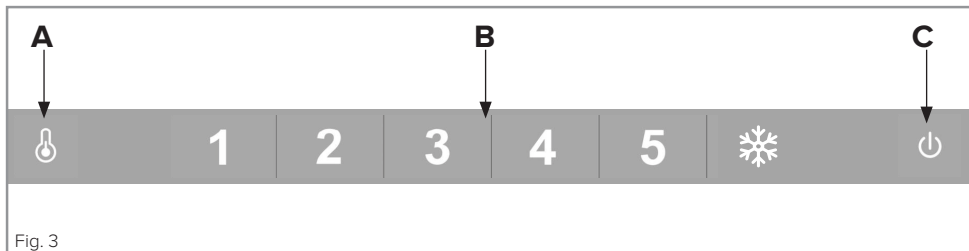

A. Freezer temperature adjustment sensor

This button is used to adjust the temperature within the freezer. Press this sensor once to activate adjustment, and then as many times as necessary until the desired level is selected. The settings range from 1 to super freeze (snowflake) with 1 being the warmest and super freeze being the coldest.

Please note: Where possible, avoid having the temperature setting on 5 or super freeze (snowflake) all of the time. This will help to alleviate strain on the compressor and system.

B. Freezer temperature setting display

This display will illuminate the current temperature setting. Adjusting the temperature will cycle through this display.

Please note: You do not use numbers 1 to 5 or the snowflake to change the temperature. Instead, use the freezer temperature adjustment sensor (**A**).

C. Power button

Use this sensor to switch the appliance on and off (standby mode). The sensor will be illuminated when the appliance is off.

Care and cleaning

Always disconnect the appliance from the power supply before any cleaning or maintenance.

The drawer sections should be cleaned using a solution of bicarbonate of soda and lukewarm water. Do not use abrasive products or detergents. After washing, rinse and dry thoroughly.

Clean the compartments separately by hand with a mild solution of washing up liquid and water. Do not use abrasive cleaners or detergents.

If the appliance is not to be used for prolonged periods of time, unplug and clean the appliance. The doors should be left slightly ajar to prevent the formation of mildew and unpleasant odours.

Defrosting the freezer

The freezer is self-defrosting. Any water created will run out through the channel at the back of the freezer, unless the drain hole is blocked. The defrosted water is collected in the evaporating tray at the back of the appliance and dissipated by evaporation (when the compressor gets hot).

Please note: If you are regularly finding pools of water in the freezer, frost build-ups, or you notice that the compressor is always running, then it is likely that the door is not sealing properly. This could be due to a defective door seal or an incorrectly fitted, or overly heavy, decor door. For more information see the troubleshooting section on ice on page 12.

Climate range

The information about the climate range of the appliance is provided on the rating plate. It indicates at which ambient temperature (that is room temperature in which the appliance is working) is optimal for the operation of the appliance.

Climate class		Allowable ambient temperature
SN	Extended Temperate	This refrigeration appliance is intended for use at an ambient temperature ranging between 10°C and 32°C
N	Temperate	This refrigeration appliance is intended for use at an ambient temperature ranging between 16°C and 32°C
ST	Sub Tropical	This refrigeration appliance is intended for use at an ambient temperature ranging between 16°C and 38°C
T	Tropical	This refrigeration appliance is intended for use at an ambient temperature ranging between 16°C and 43°C

Troubleshooting

If you have any problems with your appliance, you should check the troubleshooting prior to calling CDA Customer Care.

If the appliance is not working, check:

- That there is power to the appliance.
- The house fuses are intact and the fuse in the plug has not blown.
- The freezer has not been turned off (page 9).
- The plug socket is functioning fine. To check this, plug another electrical appliance in to see if the socket is faulty.

If the appliance is working, but not very well, check:

- The appliance is not overloaded.
- The thermostat is set to an appropriate temperature.
- The doors are closing properly.
- The cooling system at the rear of the appliance is clean and free of dust, and not touching the rear wall.
- There is enough ventilation at the side and rear walls.
- This can be due to the decor door(s) not being properly fitted, causing the freezer door to not close properly thus letting warm air in. If you are at all unsure, ask your fitter to check the decor doors.

If the appliance is noisy, check:

- The appliance is level and stable.
- The side and rear walls are clear, and there is nothing resting on the appliance.
- Note: The cooling gas in the system may make a slight bubbling or gurgling noise, even when the compressor is not running.

If the appliance is beeping, check:

- That the door is closed. An alarm will sound after approximately 60 seconds of a door being open.

If there's water in the base of the freezer, check:

- Check that there is some resistance when opening the door of the appliance. If it opens at the slightest touch it may mean that the door seal needs to be replaced.
- Check the door seal for any kinks, debris or damage. If you notice any, and are unable to resolve the issue yourself, contact CDA Customer Care so that the seal can be replaced.
- This can be due to the decor door(s) not being properly fitted. If you are at all unsure, ask your fitter to check the decor doors.

If excessive ice has formed in the freezer:

- It is normal for some ice to form in the freezer. This does not constitute a fault with the appliance.
- Check that there is some resistance when opening the door of the appliance. If it opens at the slightest touch it may mean that the door seal needs to be replaced.
- Check the door seal for any kinks, debris or damage. If you notice any, and are unable to resolve the issue yourself, contact CDA Customer Care so that the seal can be replaced.
- This can be due to the decor door(s) not being properly fitted. If you are at all unsure, ask your fitter to check the decor doors.

Installation preparation

This appliance must never be installed close to heat sources, e.g. heating elements or cookers, nor in damp places.

Seek the help of another individual, or two, when installing this appliance. This appliance may have sharp edges. Wear adequate PPE for the task and environment.

- To ensure the appliance is level, you should use the height adjustable feet at the front of the appliance.
- The cooling system at the rear of the appliance must not touch the rear wall. The greater the gap, the better.
- The appliance must be installed with adequate ventilation. Ensure that there

is clearance above the appliance to allow air to escape and that there is space between the rear of the appliance and the wall.

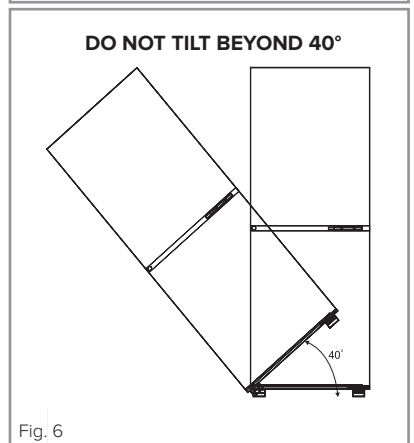
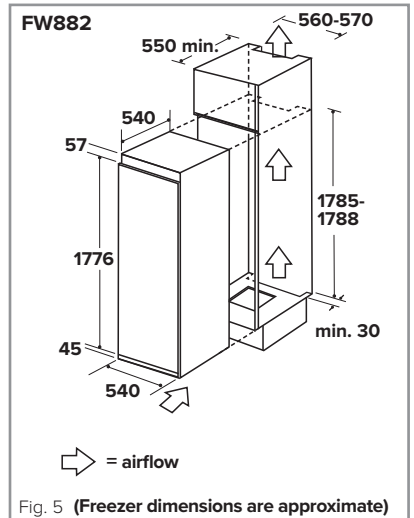

Ventilation

The main consideration when installing any refrigeration unit into a fitted kitchen is ventilation. The heat removed from the cooling compartment needs to be dissipated into the atmosphere. Incorrect ventilation can lead to premature compressor failure, excessive power

consumption, total system failure and may invalidate the warranty provided with the appliance. For products intended to be installed into a tall housing unit, the following requirements need to be met:

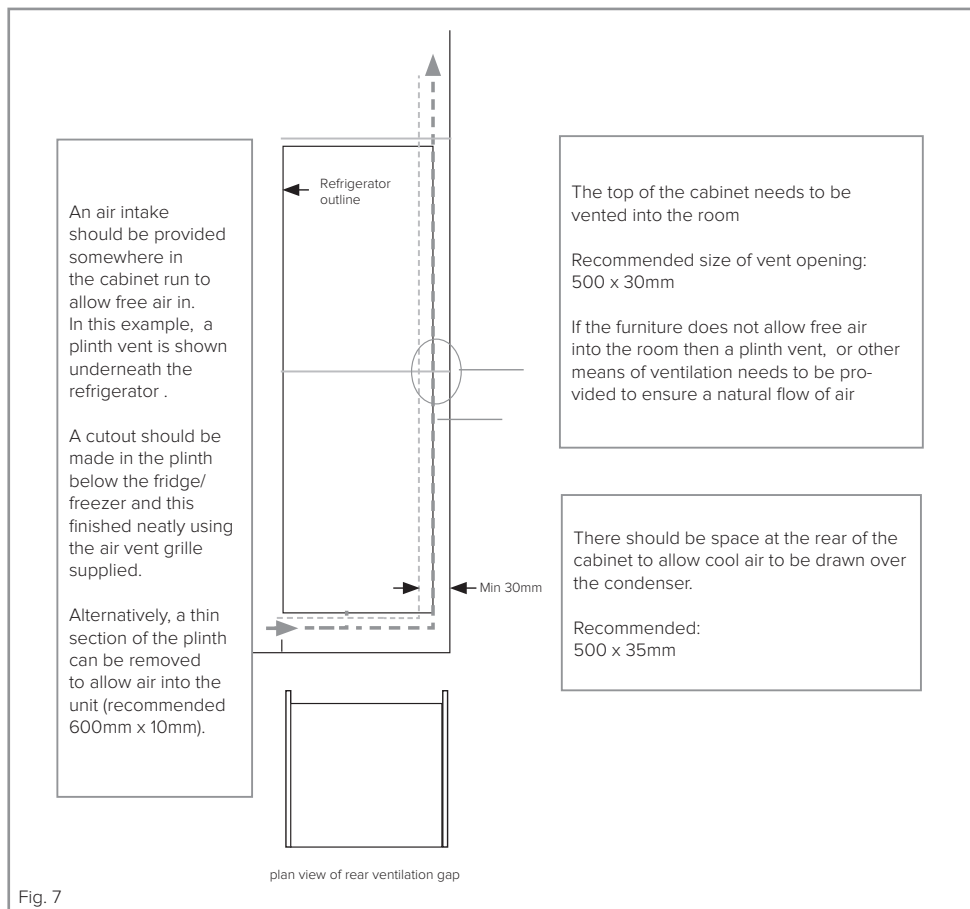

The open channel at the rear is clearly shown. For the correct operation of the appliance it is important that the top of the housing unit is not blocked off. A channel depth of 40-50mm is normal with most units.

A ventilation hole is required in the plinth of the unit; this allows air to

be drawn over the compressor & heat exchange. A decorative grille is supplied with the appliance to finish this vent neatly. Alternatively the required air flow can be achieved by removal of a thin section of plinth (recommended 600mm x 10mm minimum).

As a rule, the more air that can get in and out, the better and more efficient the operation of the product.

Installation into the cabinet

With the help of another individual, or two, manoeuvre the appliance into the cabinet. There are two metal plates at the base of the appliance. Fit the supplied white spacers (Fig. 8) to these plates, as per Fig. 9.

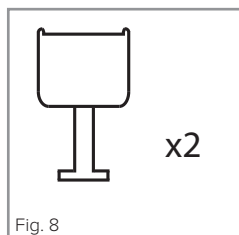

Ensure that the lips of the spacers are level with the lip of the cabinet base.

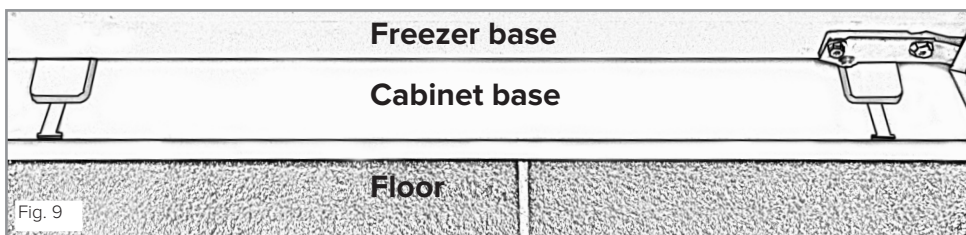

With the base of the appliance aligned correctly with the edge of the cabinet base, the metal trim at the top of the appliance should sit flush against the cabinet edge (if it does not, ensure the base is aligned as per Fig. 9 and that the metal trim in Fig. 10 is not damaged).

Secure the top of the appliance to the top of the cabinet through the metal trim screw holes marked 'T' in fig 10.

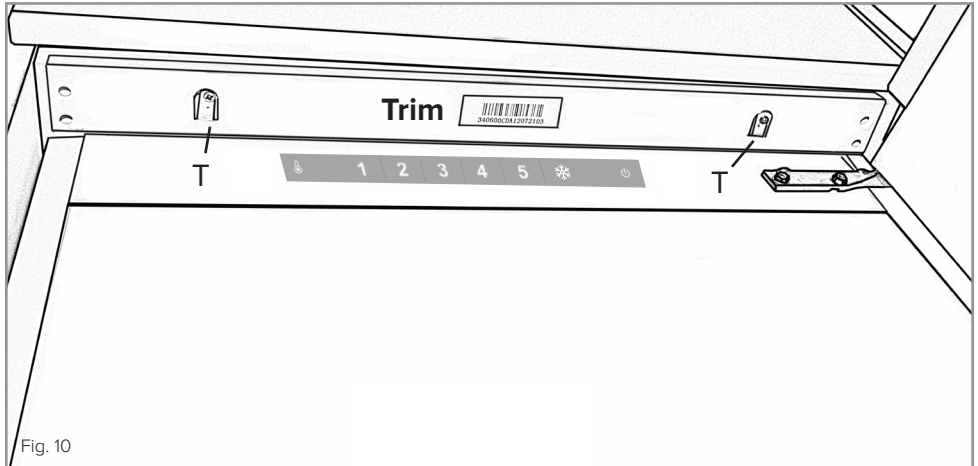

Remove the white spacers from the base plates and secure the plates to the cabinet base using four of the supplied screws. Replace the spacers.

Mounting the fascia door

- Ensure that there is a gap of 3 to 4mm between the non-hinged side and the cabinet wall.
- Locate the slider in the bracket and fix the slider to the fascia door 20 to 22mm from the edge of the fascia as shown in figure 11, ensuring that the slider is positioned centrally and horizontally within the bracket. Tighten securely by hand.
- Fill the gap on the non-hinged side with the gasket/seal strip provided, as shown in Fig. 12 (page 18).
- The finished look for the door sliders should be similar to those shown in Fig. 14, which shows 2 sliders in place.
- **Ensure the appliance door opens, closes and seals properly.**

Once complete, and if you are happy with the fit of the appliance in the cabinet, bend and snap the parts of the white spacers marked 'S' as shown by the dotted outline in fig. 13. Leave the rest of the spacer cover in place over the metal plates.

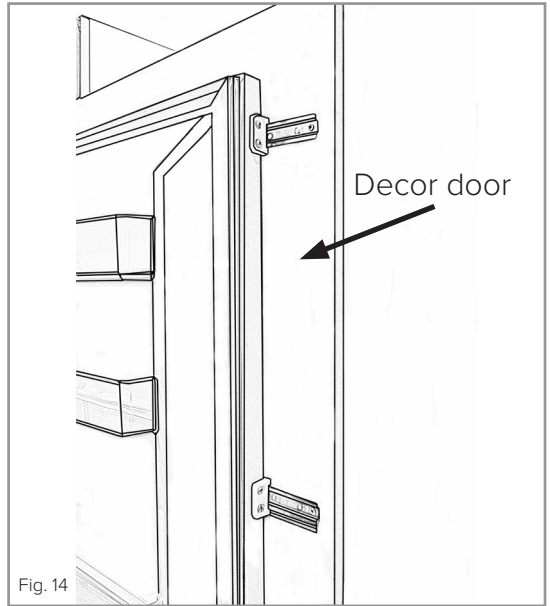
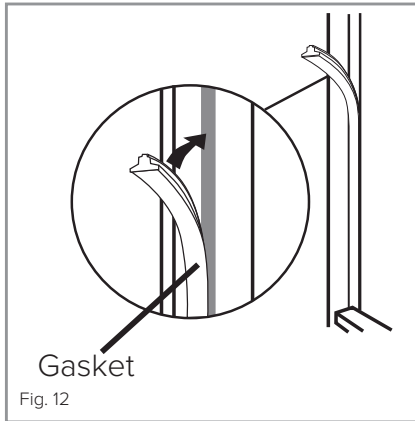
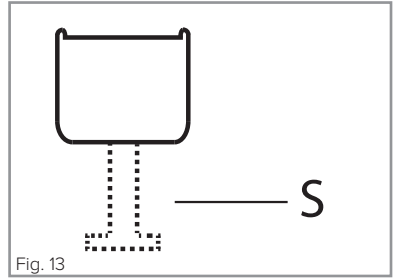
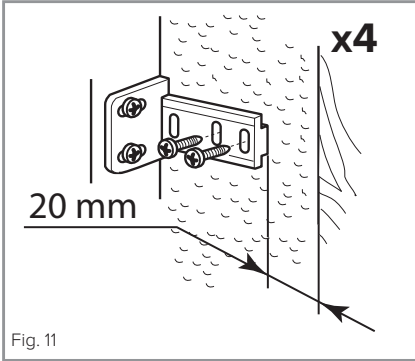

Important: After completing the installation, check that the appliance is secured within the unit and that the door(s) close and open properly. If there is no resistance from the door seals when opening the doors, then it is probable that the appliance and/or decor doors are not fitted properly.

Reversing the appliance door

We recommend you seek the help of another individual to support the doors whilst performing this operation. Always wear adequate PPE (Personal Protective Equipment) for the task at hand. Prepare a surface with a soft, clean towel or similar where you can place the door during these steps.

1. Carefully prise off the cover cap for the top hinge and unscrew the screws fixing the top hinge to the appliance, you should support the door whilst doing this.
2. Carefully remove the door from the bottom hinge (by lifting) and place it somewhere safe. Note that there may be spacers between the door and the hinge; note how many and their position.
3. Swap the previous top hinge to the opposite side at the bottom.
4. Place the door onto the new bottom hinge. Support it.
5. Refit the “new” top hinge and fix securely to the appliance.
6. Fit the central cover caps and top hinge cover pieces in place to complete the process.
7. Unscrew all four slider brackets from the door and swap them over to the side furthest from the new hinge positions, before the decor door is fitted.

Ensuring the door seals correctly:

It is normal for the seal to be compressed after the door has been reversed. With the door closed, use a hair dryer to expand the seal and fill the gap between the door and the body of the appliance. Take care not to use the hair dryer too close to the appliance, which could damage the seal. A distance of approximately 10cm should be adequate. When completed, allow the seal and door to cool before touching them. Once done, the seal should remain in position.

Electrical information

Warning! This appliance must be earthed.

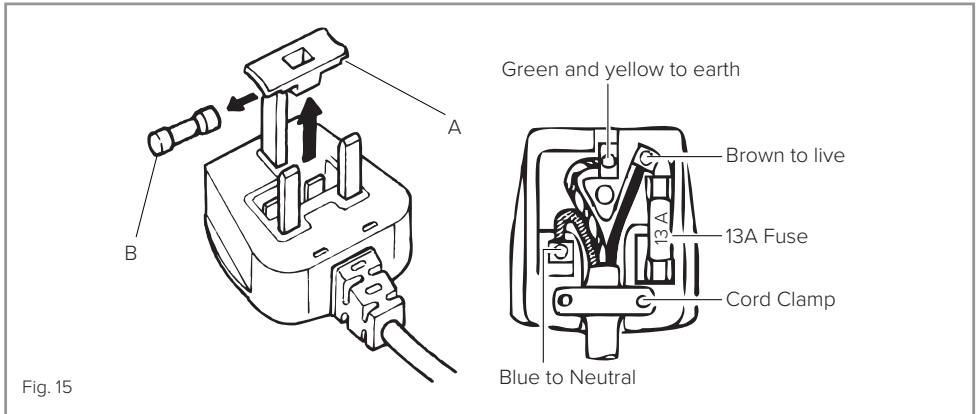

The mains lead of this appliance has been fitted with a BS 1363A 13 Amp fused plug. To change a fuse in this type of plug, follow the steps below:

1. Remove the fuse cover and fuse.
2. Fit replacement 13A fuse, ASTA approved to BS 1362 type, into the fuse cover.
3. Replace fuse cover.

Important: Do not use the appliance without the fuse cover in position.

How to connect an alternative plug

If the fitted plug is not suitable for your socket outlet, then it should be cut off and disposed of safely to avoid possible shock hazard. A suitable alternative plug of at least 13 Amp rating to BS 1363 should be used.

As the colours of the wires in the mains lead of this appliance may not correspond with the coloured markings identifying the terminals in your plug, proceed as follows:-

- The wire which is coloured GREEN and YELLOW must be connected to the terminal which is marked with letter (E) or by the Earth symbol  or coloured GREEN and YELLOW.
- The wire which is coloured BLUE must be connected to the terminal which is marked with the letter (N) or coloured BLACK.
- The wire which is coloured BROWN must be connected to the terminal which is marked with the letter (L) or coloured RED.

If in doubt regarding the electrical connection of this appliance, consult a qualified electrician. Do not shorten the supply cable, the appliance may require removing for servicing.

N.B. Ensure that the plug socket is situated in an easily accessible place after installation.

Warranty and service

The manufacturer shall not be held liable for any damage caused by improper use of the product.

- Repairs carried out by unqualified persons may seriously endanger the appliance user
- Pursuant to Commission Regulation (EU) 2019/2019, The minimum availability period for spare parts necessary to repair the appliance is 7 or 10 years depending on the type and purpose of the spare part
- The list of spare parts and the ordering procedure are available on the websites of the manufacturer, importer or an authorised representative
- The minimum warranty period for the appliance offered by the manufacturer, importer or authorized representative is given in the warranty card
- The warranty shall be void if you make any independent adaptations or alterations, tamper with seals or other appliance safety devices or its parts or interfere with the appliance contrary to operating instructions

For more information about the product, please refer to the EU EPREL Product Database at <https://eprel.ec.europa.eu>.

Alternatively you can use your mobile device to scan the QR code on the energy label or enter the product model listed on the energy label in the EPREL search engine.

Notes



For service or queries relating to your product please contact:

The Customer Care Department on **01949 862 012** or email customer.care@cda.co.uk

For more information please contact:

The Sales Department on **01949 862 010** or email sales@cda.co.uk

Customer Care Department. The CDA Group Ltd, Harby Road, Langar, Nottinghamshire, NG13 9HY
T: 01949 862 012 F: 01949 862 003 E: customer.care@cda.co.uk