



ECHK90 & ECPK90 Extractors

Installation, use and maintenance



Contents

- 3 Important information
- 4 Important notes
- 5 Using your extractor
- 6 Care and maintenance
- 7 Changing the charcoal filter
- 8 Mounting your extractor
- 9 Ducting
- 10 Installation
- 13 Mains electricity connection
- 14 Electrical information
- 14 Troubleshooting
- 15 Energy efficiency information

Important

The CDA Group Ltd cannot be held responsible for injuries or losses caused by incorrect use or installation of this product. Please note that CDA reserve the right to invalidate the guarantee supplied with this product following incorrect installation or misuse of the appliance or use in a commercial environment.

This appliance is not designed to be used by people (including children) with reduced physical, sensorial or mental capacity, or who lack experience or knowledge about it, unless they have had supervision or instructions on how to use the appliance by someone who is responsible for their safety.

Under no circumstances should any external covers be removed for servicing or maintenance except by suitably qualified personnel.

Appliance information:

Please enter the details on the appliance rating plate below for reference, to assist CDA Customer Care in the event of a fault with your appliance and to register your appliance for guarantee purposes.

Appliance Model	
Serial Number	

EU Declarations of Conformity:

This appliance has been designed, constructed and marketed in compliance with safety requirements of EU Directive 2014/35/EU (LVD) and requirements of EU Directive 2014/30/EU (EMC).

IMPORTANT INFORMATION FOR CORRECT DISPOSAL OF THE PRODUCT IN ACCORDANCE WITH EC DIRECTIVE 2012/19/EU.

At the end of its working life, the product must be taken to a special local authority waste collection centre or to a dealer providing appliance recycling services.

Disposing of a household appliance separately avoids possible negative consequences for the environment and health. It also enables the constituent materials to be recovered, saving both energy and resources. As a reminder of the need to dispose of household appliances separately, the product is marked with a crossed-out wheeled dustbin. 

Please note:

- Under no circumstances should the extractor be connected to any gas ventilation system, flue system or hot air ducting system.
- Do not vent the extractor into an attic or loft space.
- Only house the extractor in rooms with adequate ventilation. Remember that the extractor is powerful and whatever air is extracted needs to be replaced.
- Do not tile the extractor in. It should be removable for service or maintenance.
- Do not use silicone sealant to secure the hood to the wall.
- You must be able to isolate the extractor from the mains electrical supply after installation.
- This extractor has been designed to be used in a room with a volume of less than 36m³.
- Steam cleaners must not be used when cleaning this appliance.
- The performance of your extractor will vary depending on a number of factors. These include: type of extraction, length of ducting, room volume, ventilation available and cleanliness of the filters.

Using your Extractor

For best performance, you should switch on the extractor 15 minutes before starting to cook and leave it to run for approximately 15 minutes after the end of cooking.

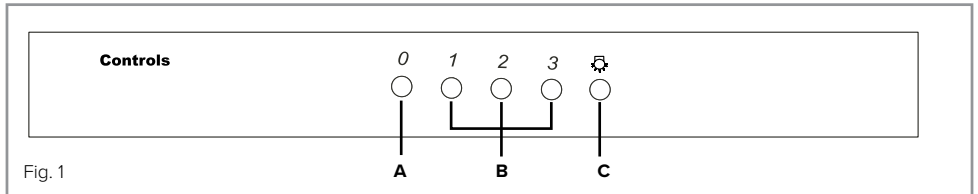

Control Panel

- A - Power off button
- B - Speed level buttons
- C - Light button

To switch the extractor light on or off

- Press button “C”.

To switch on the extractor or to change the speed at any time when the extractor is running

- Press the relevant “B” button for the first, second or third speed level as required.

To switch the extractor off

- Press the “A” button.

Care and Maintenance

IMPORTANT: DO NOT PERFORM MAINTENANCE OR CLEANING OF THE EXTRACTOR WITHOUT FIRST SWITCHING OFF THE ELECTRICITY SUPPLY.

Cleaning

You should use a non-abrasive cleaner. Any abrasive cleaner (including Cif) will scratch the surface and could erase the control panel markings.

You can clean you extractor effectively by simply using a dilute solution of water and mild detergent and drying to a shine with a clean cloth, for example the CDA E-Cloth.

We recommend always wearing PPE (Personal Protective Equipment) when carrying out any cleaning or maintenance.

IMPORTANT:

- **Steam cleaners must not be used when cleaning this appliance.**
- **Once care and maintenance is complete, ensure that all parts are correctly replaced before using the extractor.**

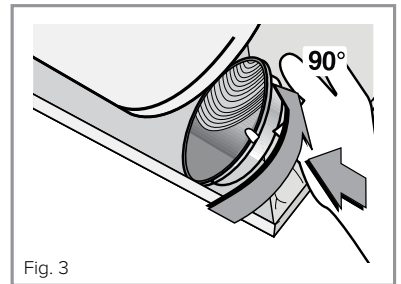
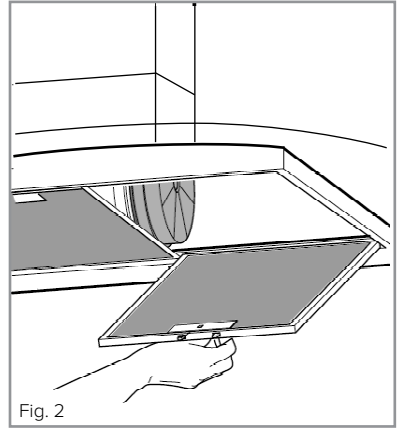

Cleaning the grease filter

The grease filters should be kept clean to minimise the risk of fire. At least once a month you should remove and clean the grease filters with hot soapy water. You can also wash the grease filters in a dishwasher, ensuring that you place it in an upright position to prevent damage from other items in the dishwasher. After rinsing and drying, replace the filters.

To remove the grease filters, pull open the handle on the grease filter. It will release at the handle side. Then lower the grease filter to remove it completely (fig. 2). To replace the grease filter, repeat the steps in reverse.

Please note:

Cleaning the grease filters in the dishwasher may lead to discolouration. This is normal and does not constitute a fault with the appliance.

Changing the charcoal filter (re-circulating only)

To ensure best performance of your extractor, you should replace the charcoal filters every four to six months, depending on use.

To attach a new charcoal filter, first remove the grease filters as described above. Then offer up the charcoal filter to the side of the motor as shown in figure 3 and turn it clockwise until it locks into place. Repeat with the other charcoal filter on the other side of the motor. Then replace the grease filters and cover panels.

Changing the light

This appliance is fitted with energy saving LED lighting that has a considerably longer life expectancy than traditional filament bulbs. These are not user-replaceable in the unlikely event of a failure.

Do not touch bulbs or adjacent areas during or straight after prolonged use of the lights. The light is designed for use during cooking and not for general room illumination. Extended use of the light can reduce the life span of the bulb.

Mounting your extractor

When the extractor is to be installed above an electric hob, the minimum distance between the hob and extractor must exceed 600mm (650mm is recommended).

When the extractor is to be installed above a gas hob, the minimum distance between the hob and extractor must exceed 700mm (750mm is recommended).

If the instructions provided with your gas hob state that the required distance between the hob and extractor must be greater than 700mm, then that is the distance that should be observed; this is a legal requirement and may lead to your hob being disconnected from the gas supply and the installation being reported under RIDDOR (The height should be measured from the top of the burners).

IN THE ABSENCE OF ANY INSTRUCTIONS SUPPLIED WITH THE GAS HOB, THE MINIMUM DISTANCE BETWEEN THE HOB AND EXTRACTOR MUST BE AT LEAST 760mm.

The width of any hob must not be greater than the width of the extractor installed above it.

Ducting and ventilation

For best performance and lowest noise output, we recommend the use of 150mm ducting. You can also use 120mm ducting but this will reduce performance. In general, the less ducting you use (i.e. distance and bends) the more efficient your extractor will be.

The lengths of ducting with minimal effect on performance are as follows:

- 4 metres with 1 x 90° bend.
- 3 metres with 2 x 90° bends.
- 2 metres with 3 x 90° bends.

Longer ducting can be used but the performance of the extractor will likely be reduced.

Please note: Ducting components and ducting kits are optional accessories and have to be ordered, they are not automatically supplied with the hood. Use of ducting less than 150mm in diameter will affect performance and increase the noise produced by the extractor.

Installation

Note

- We recommend that you seek the help of another individual when installing this product. Always wear adequate PPE (Personal Protective Equipment).
- The fixings supplied are suitable for most installations. It is the responsibility of the installer to ensure that the fixings are suitable for the ceiling type in the property.

Installation steps

1. Firstly, fix the vent outlet to the extractor body using four screws, as shown in fig 5.
2. Using the supplied template, mark the positions of the ceiling mounting screws and the cut-out for the ducting pipe, if required.

Fix four suitable wall plugs into the holes and proceed to assemble the extractor, as described in fig 6.

3. To determine the overall height of

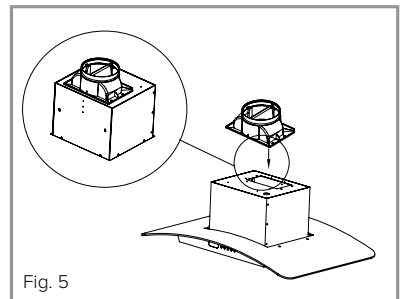
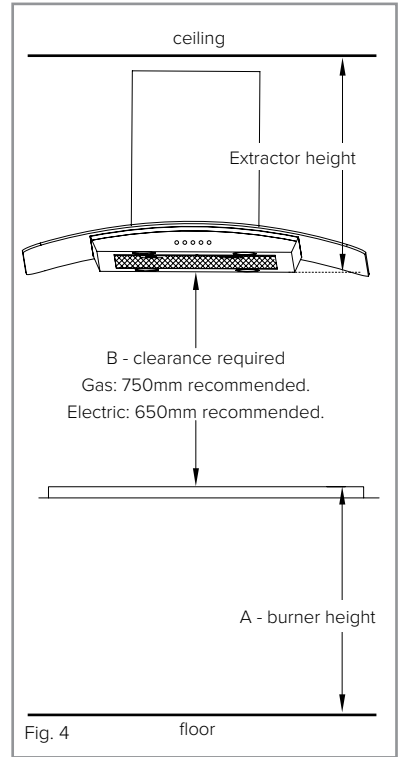

Fig. 5

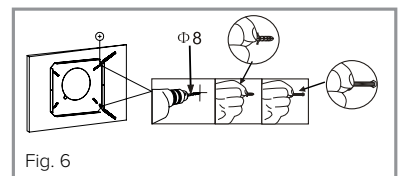

Fig. 6

the chimney section, use the calculation shown on this page for your extractor (also refer to fig 4):

A = Height of gas hob burner or electric hotplate height from the kitchen floor

B = Clearance required:

Gas hobs 750mm recommended

Electric hobs: 650mm recommended

A+B is the required height of the body of the extractor above the floor.

Next we need to calculate the required height of the extractor.

Whole extractor height = ceiling height - height above floor (A+B).

4. Assemble the chimney sections 1, 2, 3 and 4 on the diagram fig 7, using the supplied fixing screws and fix to the chimney body. Measure the height of the chimney and ensure that it is equal or less than the height calculated in step 3. (When the extractor is mounted the height between the hob and extractor must

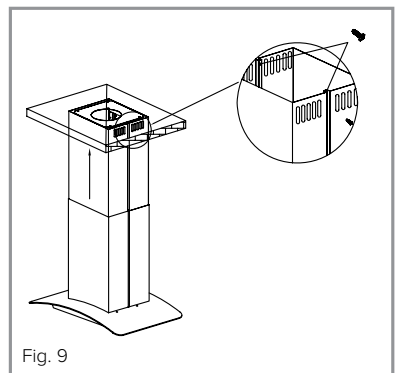
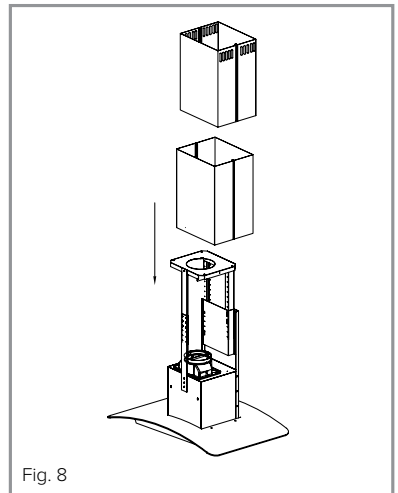
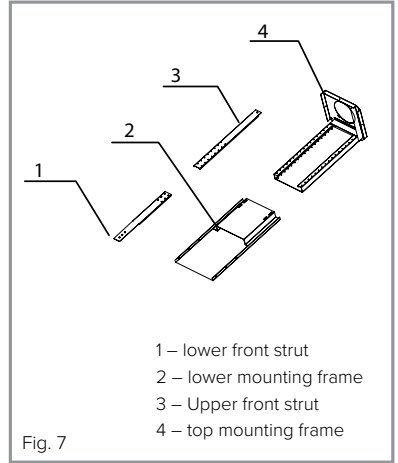

be at least the minimum height specified).

5. Place the chimney section over the body assembly, as shown in fig 8.
6. With the help of another individual, raise the whole assembly to the ceiling and fix securely in place using four screws appropriate for the wall plugs inserted in step 2. Ensure that the supporting ceiling is strong enough to take the weight before releasing the extractor.
7. Connect the ducting to the extractor vent outlet, securing it in place with a cable tie, duct tape or other suitable means.
8. Finally, raise the inner section of the chimney to the ceiling and secure in place using the two small screws supplied
9. Note that the electrical connection to the extractor should not be located inside the boundaries of the chimney. This is especially important if the extractor is to be used as a recycling device. There should be an isolation switch so that the extractor can be disconnected from the mains electrical supply after installation.

The metal casing of this appliance has been coated with a preservative to protect it during transport and storage. This should be removed during installation by using a non-abrasive stainless steel cleaner. Always follow the instructions given with the cleaner being used.

Mains Electricity Connection

THIS APPLIANCE MUST BE CONNECTED TO THE MAINS SUPPLY BY A COMPETENT PERSON, USING FIXED WIRING VIA A DOUBLE POLE SWITCHED FUSED SPUR OUTLET AND PROTECTED BY A 3A FUSE.

We recommend that the appliance is connected by a qualified electrician, who is a member of the N.I.C.E.I.C. and who will comply with the I.E.E. and local regulations.

The wires in the mains lead of this appliance are coloured in accordance with the following code:

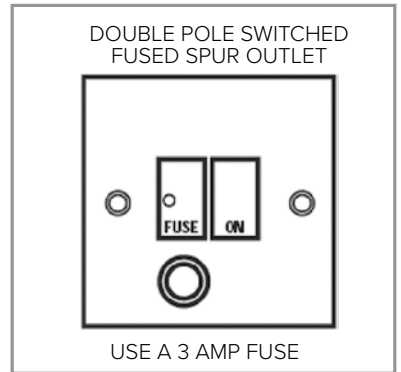

BLUE = NEUTRAL, BROWN = LIVE, GREEN+YELLOW = EARTH

As the colours of the wires in the mains lead for the appliance may not correspond with the coloured markings identifying the terminals connecting to the fused spur, proceed as follows:

- The wire which is coloured blue must be connected to the terminal marked N (Neutral), or coloured black.
- The wire which is coloured brown must be connected to the terminal marked L (Live), or coloured red.
- The wire which is coloured green and yellow must be connected to the terminal marked E (Earth) or coloured green or green and yellow.

Assembly and electrical connection should be carried out by competent personnel.

When installing this product we recommend you seek the help of another individual.

Do not mount the isolation switch behind the chimney section. It is a requirement that you must be able to isolate the extractor from the mains electrical supply after installation.

This appliance is intended to be connected to the mains electrical supply by means of an isolation switch and fused spur and is intended to be protected by a 3A fuse. The use of a 13A fuse can cause damage to the internal wiring in the event of a fault, and may also invalidate the warranty. **NOTE: USE A 3A FUSE**

Electrical Information

Mains electrical voltage: 230 – 240Vac.

Total rated power consumption: ECHK90: 104W
ECPK90: 108W

Troubleshooting

If your extractor is not working:

1. Check that the mains supply has not been switched off.
2. Check that the fuse in the spur has not blown.

Contact CDA Customer Care

A: Customer Care Department, The CDA Group Ltd, Harby Road,
Langar, Nottinghamshire, NG13 9HY

T: 01949 862 012

F: 01949 862 003

E: customer.care@cda.eu

W: www.cda.eu

Energy Efficiency Information

Attribute	Symbol	Value		Units
Model Identification		ECHK90	ECPK90	
Annual Energy Consumption	AEC_{Hood}	57.1	63.7	kWh
Time increase factor	f	1.6	1.7	
Fluid Dynamic Efficiency	FDE_{Hood}	10.0	8.4	
Energy Efficiency Index	EEl_{Hood}	83.4	89.7	
Measured airflow at Best Efficiency Point	Q_{BEP}	226.0	224.3	m^3/h
Measured Pressure at Best Efficiency Point	P_{BEP}	148.0	126.0	Pa
Maximum airflow	Q_{MAX}	404.4	387.4	m^3/h
Measured electric power at Best Efficiency Point	W_{BEP}	92.7	93.3	W
Nominal lighting power	WL	4	8	W
Average illumination of the lighting system on the cooking surface	E_{Middle}	202	730	Lux
Measured power consumption in standby	P_S	NA	NA	W
Measured power consumption off mode	P_O	0.0	0.0	W
Sound power level	L_{WA}	61.0	61.0	dBA
Grease Filter Efficiency	GFE_{Hood}	69.5 (D)	69.7 (D)	%
Lamp efficiency	LE_{Hood}	50 (A)	91 (A)	%

E & O E. All instructions, dimensions and illustrations are provided for guidance only. CDA reserve the right to change specifications without prior notice.



For service or queries relating to your product please contact:

The Customer Care Department on **01949 862 012** or email customer.care@cda.eu

For more information please contact:

The Sales Department on **01949 862 010** or email sales@cda.eu

Customer Care Department. The CDA Group Ltd, Harby Road, Langar, Nottinghamshire, NG13 9HY
T: 01949 862 012 F: 01949 862 003 E: customer.care@cda.eu