



*Built for your life*

**For Technical Support Call :** 01949 862012

**Fax:** 01949 862003

**Email :** customer.care@cda.eu

## TC61 – Single lever swan neck tap

### 5 Year warranty:

Please register your tap with CDA Customer Care using the contact details above to be eligible for the following warranty; In the unlikely event that you should experience any defect in the materials or workmanship of your new CDA tap within FIVE years of purchase, the purchaser's sole remedy shall be the replacement (at the manufacturer's discretion) of all or any part of the product that is defective. This is provided that the tap has been used for normal domestic purposes in the UK and that the care, installation and maintenance instructions have been observed. The warranty extends to the original purchaser only. You should retain a copy of your dated invoice as proof of purchase to validate any claims under this guarantee.

### Care instructions for your tap:

To maintain the appearance of this tap, ensure that it is regularly cleaned using only a clean, soft damp cloth. A solution of warm water and a mild liquid detergent may be used where necessary, and then rinsed thoroughly and wiped dry. Any other cleaning action will invalidate your warranty. If the tap has a diffuser it should be cleaned periodically.

Abrasive cleaners, scouring cleaners and acidic cleaners must not be used under any circumstances. Avoid contact with all solvents (including chlorinated solvents, ketones or acetones as these may result in surface deterioration or etching). Also avoid contact with any harsh household chemicals such as oven cleaners, drain cleaners, rust removers, paint strippers, toilet bowl cleaners, bar keepers friend or Brasso.

### Important technical data:

Minimum operating pressure: 0.5 bar

Maximum hot water temperature: 70°C

Maximum operating pressure: 8 bar\*

Recommended hot water temperature: 46°C

**\* If these temperatures or pressures are exceeded, even for short periods, damage can result.**

CDA taps are either WRAS approved or manufactured in accordance with recognised European standards. Please ensure your kitchen tap is fitted in accordance with Local Water Byelaws. These installation guidelines have been prepared for your direction and you must exercise care at all times. We do not accept responsibility for problems that may occur through improper installation. Whilst assembling the tap, take care not to accidentally loosen any screwed assemblies.

### Installation preparation:

- Before installing the new mixer it is essential that you thoroughly flush through the supply pipes in order to remove any remaining solder, swarf or impurities from your system. Failure to carry out this simple procedure could cause problems or damage the workings of the tap. **Ensure that you remove these impurities from the sink below too. Failing to do so can damage the sink.**
- We strongly recommend installing particle filter strainers and isolation valves to both the hot and cold feed pipes in an accessible position. This will help to prevent premature failure of the valves and ease any future maintenance.
- **All parts should be removed from their packaging and inspected for any transport damage prior to installation.**
- Shut off your water heating system and ensure that your mains stopcock is closed. Open the lowest hot and cold taps in the house and allow the water to run until the cold-water storage tank and pipes are fully empty. Please note, the hot water storage cylinder (if applicable) will always remain full.
- This tap requires a 35mmØ tap hole. If replacing an existing tap, remove the tap & clean the end of the feed pipes using wire wool. The tap hole area should be free from dirt and sealant.
- Loosely position the tap and tail pipes to check if any alteration to the existing pipework is required. If this is the case, do this now.

**Installation:**

1. Fit the flexible hoses (part 19) to the tap. We recommend using a small amount of PTFE tape to help keep a good seal.
2. Connect part 12 to the base of the tap.
3. Feed the tap, hoses and threaded insert (part 12) through the worktop, taking care not to damage the tap assembly or worktop.
4. Assemble parts 13, 14, 15 (stabiliser), 16 and 17 if required, as per the image below and fit them onto the threaded insert.
5. Attach and tighten the fixing nut (part 18) to secure the assembly to the worktop.
6. Ensure the flexible hoses are tightened within the tap but **do not overtighten them** as this could damage the seals.
7. Connect the hot and cold tail pipes to the water mains using suitable fittings.

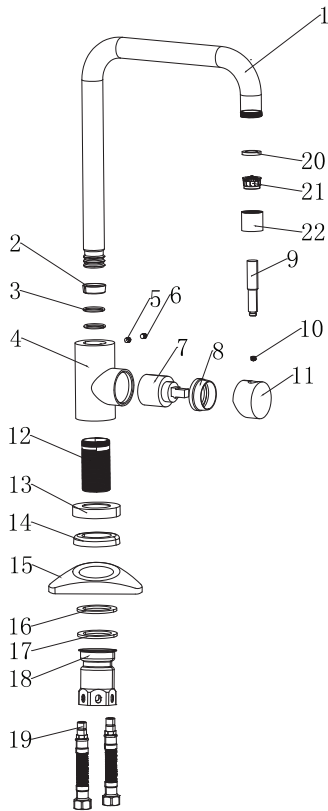

Key	Part Description	QTY
1	Spout	1
2	Ring	1
3	O-ring	2
4	Tap body	1
5	Hex (grub) screw	1
6	Cap	1
7	Cartridge	1
8	Cartridge nut	1
9	Handle lever	1
10	M5 screw	1
11	Handle body	1
12	Screw fitting	1
13	Base cover	1
14	Rubber washer	1
15	Stabilizer	1
16	Flat rubber washer	1
17	Washer	1
18	Nut	1
19	Flexible hose	2
20	Flat rubber washer	1
21	Aerator	1
22	Aerator housing	1

**After installation:**

Once you have visually checked the new fittings and connections, ensure that all taps are closed except the new tap, which should be left open. Turn on the water supply at the mains stop cock. As the system starts to refill, check carefully for leaks. Once you are fully satisfied that there are no leaks, turn on the water heating.

Clean the tap to remove any marks created during installation and then replace the bag that has been provided to protect the tap until it is ready for use.