



TH101

Three in One Instant Hot Water Tap

Installation, use and maintenance



Contents:

3	Important safety warnings
5	Safety instructions
6	Important notes
7	Care and maintenance information
8	Important fire safety precautions
9	Important information
12	Using your tap
14	Care and maintenance
14	De-scaling the system
15	Steps for de-scaling the system
20	Draining the system
21	Replacing the filter
24	Installation - Important technical data
25	Installation preparation
26	Installation setup diagram
27	Installation steps - tap
28	Installation steps - boiler unit
31	Calibration procedure
33	Installation setup - final
34	Technical data (boiler unit)
35	Electrical information
37	Troubleshooting guide
44	Flow-pressure graph

IMPORTANT: Please read the user instructions carefully before using the appliance for the first time.

Important safety warnings

This appliance can be used by children aged from 8 years and above and persons with reduced physical, sensory or mental capabilities or lack of experience and knowledge provided they have been given supervision or instruction concerning use of the appliance in a safe way and have understood the hazards involved and by a person responsible for their safety. Children should not be allowed to play with the appliance. Cleaning and user maintenance should not be attempted by children without supervision.

This unit is **NOT PRESSURISED** - it is designed to be open vented. The drain valve is there to drain the tap after each use and will drip in operation which is not indicative of a fault with the appliance.

Servicing of this product must be carried out by persons having knowledge and practical experience of the appliance, in particular as far as safety and hygiene are concerned. The system contains no user serviceable parts and should only ever be serviced by the recommended service agent. For user maintenance, see page 14.

This product should only be installed into an internal domestic environment with an ambient temperature of 10-40°C. If the unit is accidentally left filled in an unheated environment for a prolonged period, do not switch it on if there is a possibility that the water inside is frozen. It must defrost naturally.

All surfaces, especially those made from metal, may become hot whilst in operation. Use caution when touching these surfaces. Inform all users that the surfaces may become hot.

Do not open the tank, drain cocks or other emptying devices until the tank has cooled to a safe temperature.

Do not use this appliance if you suspect it or any of its hoses are damaged or kinked in any way, or is performing differently from how you would expect.

Never use any appliance with a damaged mains power lead. You should immediately disconnect the power and contact the service agent noted on the top of the boiler.

Do not wash your hair, babies, children or pets in any sink within reach of this appliance. Knocking the boiling water lever, or the temperature not being calibrated as per this manual (pages 31-32), could cause scalding by uncontrolled release of boiling water.

The boiler unit is provided with approximately 1 metre of mains cable with a moulded 3 pin UK plug (fuse rating – 10 Amps).

Safety instructions

Children should be supervised to ensure that they do not play with the appliance.

Cleaning and user maintenance must not be carried out by children without supervision.

Never immerse the appliance in water.

This is a household appliance only. It is not intended to be used in:

- Staff kitchen areas in shops, offices and other working environments
- By clients in hotels, motels and other residential type environments
- Cafes, pubs, bars and other similar environments
- Bed and breakfast type environments.

Ensure that anyone new to the appliance (e.g. friends staying with you or visiting briefly) is fully briefed on the function of the tap and is aware that it will potentially dispense boiling water.

When not in use for prolonged periods, and before cleaning or maintenance, always unplug the appliance.

We recommend wearing PPE (Personal Protective Equipment) whenever you are handling, servicing or installing this product.

Important Notes:

This appliance is designed solely to dispense hot and cold water and also to produce and dispense near-boiling water. Other types of use are not permitted and may prove dangerous. The CDA Group Ltd will not be held liable for any damage caused by incorrect use of the appliance or failure to adhere to this user manual.

- To protect against fire, electrical shock and injury to persons, do not immerse cord or plugs in water or other liquid.
- The use of accessory attachments not recommended by The CDA Group Ltd may result in fire, electric shock or injury.
- Never touch the under-counter parts of the appliance with damp hands.
- Never touch the plug with damp hands.
- Make sure the socket used is freely accessible at all times, enabling the appliance to be unplugged when necessary.
- Unplug directly from the plug only. Never pull the power cable as you could damage it.
- If the appliance is faulty, do not attempt to repair it; unplug from the mains electric socket and contact the dedicated service line (details on rear cover of this user manual).
- Keep all packaging (plastic bags, polystyrene foam) away from children.
- This appliance produces very hot water; steam may form while it is in operation. Avoid contact with splashes of hot water or hot steam.
- Do not rest vessels containing liquids, inflammable or corrosive materials on top of any part of the appliance.
- Do not rest large or unstable objects on any part of the appliance.

Care and maintenance information

If the product is going to remain unused and unattended for a prolonged period, the boiler should be switched off. If the period is extended beyond a two week holiday, then we recommend that the boiler is also drained. As with any water-fed appliance, the water supplies should also be isolated in case of emergencies or service.

Whilst we do not expect you to encounter any leaks, you should regularly inspect the system for leaks. If there are any visible signs of water damage you should immediately stop using the unit and contact service (details on rear cover of this user manual).

Use of any cleaners that are acidic, abrasive, alkaline or solvent based can result in the deterioration of the components and will void the warranty.

Cleaning and user maintenance should not be performed by children without supervision.

Do not add to, exchange or modify any component of the boiler or mixer tap. The spout exit or any part of the system must not include any additional third party adaptors or connections that will add resistance to the system.

This appliance is intended to be permanently connected to the water mains.

We only warrant the original filter type supplied with your boiler which is formulated specifically for the product. If the filter is removed or exchanged for an alternative model it may have a detrimental effect to your system and would subsequently invalidate your warranty. If you have specific or unusual incoming water conditions please contact the service number on the boiler (or rear cover of this user manual) for further advice.

The boiler and mixer tap are not designed to work with any other combination of appliances other than as shown within this manual.

Important fire safety precautions

Do not store or use petrol or other flammable rags, paper, aerosols, vapours or liquids in the vicinity of this or any other appliance.

Install the unit on a heat-resistant surface. Make sure that the installation surface is firm and level.

For safety regulations the plug or means of disconnection must always be accessible after installation.

Do not use any water jet or steam near this appliance.

Important

The CDA Group Ltd cannot be held responsible for injuries or losses caused by incorrect use or installation of this product. Please note that CDA reserve the right to invalidate the guarantee supplied with this product following incorrect installation or misuse of the appliance.

The guarantee may become void in the event of the water filter not being replaced at the required six month intervals.

Under no circumstances should any external covers be removed for servicing or maintenance except by suitably qualified personnel. The exception to this is the maintenance detailed on pages 14-20.

Appliance information:

Please enter the details on the appliance rating plate below for reference when registering this appliance. This will also be useful in the event of a fault with your appliance when it is necessary to contact the dedicated service line (details on rear cover) for support and/or guarantee purposes.

Appliance Model	
-----------------	--

Serial Number	
---------------	--

EU Declarations of Conformity:

This appliance has been designed, constructed and marketed in compliance with safety requirements of EU Directive 2014/35/EU (LVD) and requirements of EU Directive 2014/30/EU (EMC).

This appliance has been manufactured to the strictest standards and complies with all applicable legislation, including Electrical safety (LVD) and Electromagnetic interference compatibility (EMC). Parts intended to come into contact with food conform to 1935/2004/EC.

IMPORTANT INFORMATION FOR CORRECT DISPOSAL OF THE PRODUCT IN ACCORDANCE WITH EU DIRECTIVE 2012/19/EU.

At the end of its working life, the product must not be disposed of as urban waste. It must be taken to a special local authority differentiated waste collection centre or to a dealer providing this service.

Disposing of a household appliance separately avoids possible negative consequences for the environment and health deriving from inappropriate disposal and enables the constituent materials to be recovered to obtain significant savings in energy and resources. As a reminder of the need to dispose of household appliances separately, the product is marked with a crossed-out wheeled dustbin. 

Page left blank intentionally

Using your 3 in 1 instant hot water tap

This product, when correctly installed, can dispense 3 types of water. Please note that the orientations in these instructions (i.e. left and right) are applicable when the tap is installed as per this manual.

Cold (domestic) water - This is delivered when the right tap handle is pulled outwards horizontally (Fig. 3) and turned 20° away from you.

Hot (domestic) water - This is delivered when the right tap handle is pulled outwards horizontally and turned fully towards you (Fig. 4). For a mixed water temperature, turn the handle approximately 45 degrees or as required.

Hot (boiled and filtered) water (denoted by a red ring around the tap lever) - This is delivered when the left tap handle is pushed downwards (Fig. 1) and turned towards you (Fig. 2). The further towards you that the lever is turned, the greater the flow shall be.

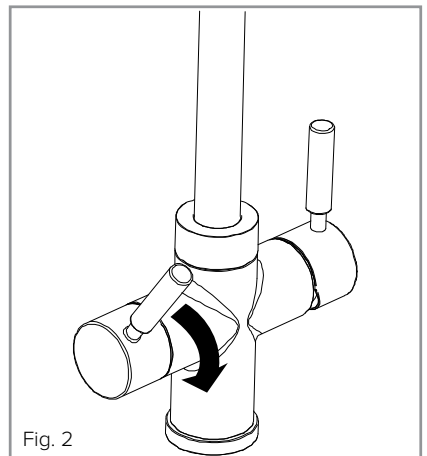
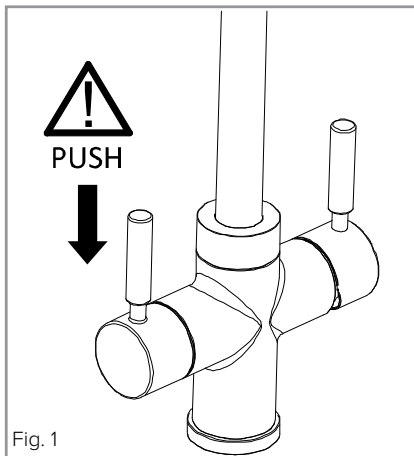

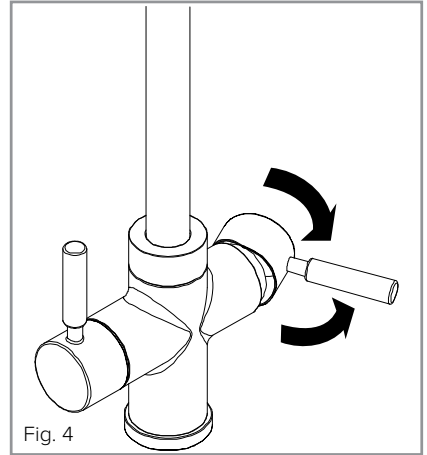
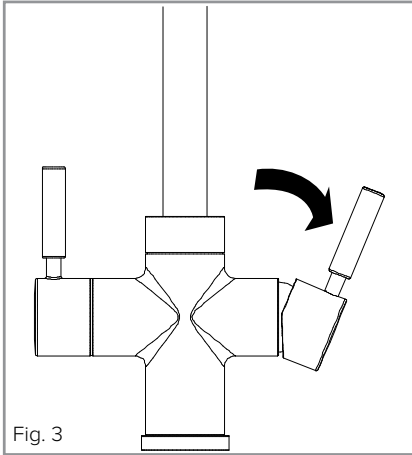

Please note:

It is normal for the hot (boiled and filtered) water to take a moment to dispense as the water empties from the system after use.

Should you see that hot water persistently drips from the centre channel of the tap spout, (when the tap is not in use and the boiler indicator red light is illuminated) then you should reduce the temperature adjustment dial on the top of the boiler. See the calibration procedure on pages 31-32 for further information.

Each time the product is used you should flush a small amount of boiled water through before use. Typically this can be used to preheat your cup. If unused for extended periods then flush the product for a longer time.

Care and maintenance

IMPORTANT: DO NOT PERFORM MAINTENANCE OR CLEANING OF THE RESERVOIR/HEATER UNIT WITHOUT FIRST SWITCHING OFF AND DISCONNECTING THE APPLIANCE FROM THE ELECTRICITY SUPPLY.

Cleaning

You should use warm water and a mild liquid detergent where necessary. Ensure the unit is dried thoroughly afterwards. Any abrasive cleaner (including Cif) will scratch the surface.

You can clean the exterior of your reservoir/heater unit effectively by simply using a cloth dampened in a dilute solution of water and mild detergent then drying with a clean cloth.

Descaling the system

The filter system provided will help to prevent the calcification (scaling) of the boiler. However, from time to time, the system will need to be descaled, drained and refilled to ensure the maximum energy efficiency and service life from the product, **especially in hard water areas**. Descaling solutions can be obtained by contacting CDA Customer Care. Contact details are on the rear cover of this manual.

Ensuring that the filter system is set up correctly and replaced, as required, will reduce the frequency of descaling required.

If you are regularly needing to descale the system then you potentially need to replace the filter more frequently or check the setup of the filter system.

The descaling chemical is acidic and should only be used and handled as indicated. Care should be taken not to ingest, expose to skin, clothing or decorative surfaces. Take care when touching all surfaces and when disconnecting or connecting hoses - they may be hot and/or generate steam. You must use personal protective wear to prevent accidental scalding.

The descalant is also an IRRITANT:

CAUTION: Harmful if swallowed. Irritating to eyes and skin. **KEEP OUT OF REACH OF CHILDREN.** Avoid contact with skin and eyes. In case of contact with eyes, rinse immediately with plenty of cold water and seek medical advice. After contact with skin, wash immediately with plenty of water. If swallowed, seek medical advice immediately and show the container or label.

MSDS Available. Ingredients: Sulfamic Acid. Country of origin USA. Visit www.cda.eu for more information.

Steps for descaling the system

Step 1:

If not already so, switch off the appliance at the plug and take the plug out of its socket.

Step 2:

Turn on the hot (boiled and filtered) water lever as per page 12. Allow the water to run until it turns cold. **Take care - the water may still be hot.** Once cold, turn the tap off.

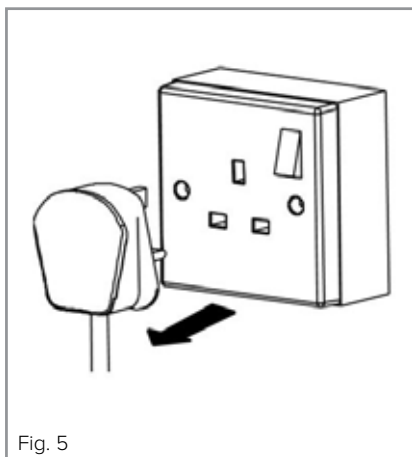
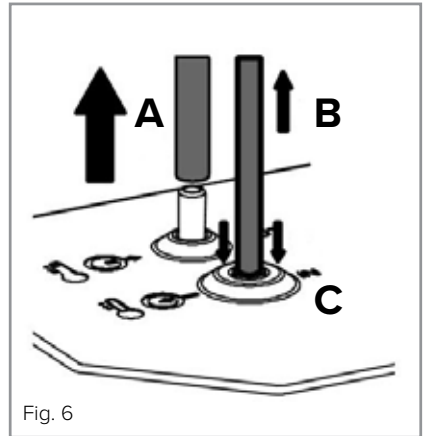

Fig. 5

Step 3:

On the water heater, find the terminal marked 'Out'. Grip and remove the rubber hose attached to this terminal (A). On the water terminal marked 'In', hold down the white collar, visible just under the terminal outlet (C), and pull the water pipe out (B). There may be some small spillages at this stage so please take necessary steps to remove them. **Move the tank to a suitable drainage location (e.g. sink or large basin).**



Step 4:

Open the drain on the front of the unit (D in Fig. 7) using a small coin or similar. Drain the tank fully. Replace the drain cover (D) and tighten once the tank has emptied.

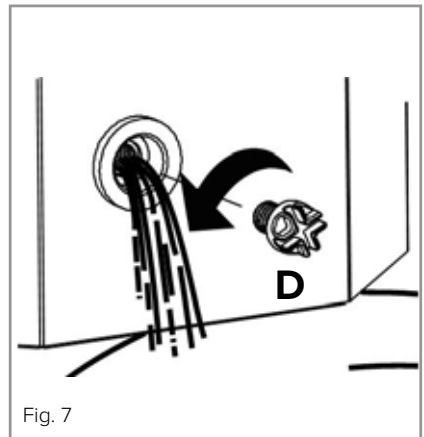

Step 5:

Lift up and remove the boiler lid (E) with temperature control dial and the styrene insulation (F) as per Fig. 8.

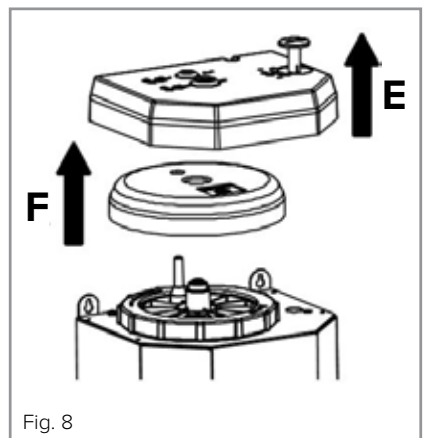

Step 6:

Unscrew the tank lid ring in an anti-clockwise direction and remove it (Fig. 9).

Step 7:

Lever the tank lid upwards using a flathead screwdriver at the 3 lug points (Fig. 10). **Use the thinnest screwdriver possible so as to prevent damage to the lid surround.**

Step 8:

Prise and lift the tank lid (Fig. 11) and rinse out the tank with clean cold water. Drain via the front drain if necessary (Step 4/Fig. 7) but remember to replace the drain afterwards.

Step 9:

Add one bottle of descaler fluid (add two if the boiling unit is heavily scaled). **Please take care not to damage the inside of the boiler tank.**

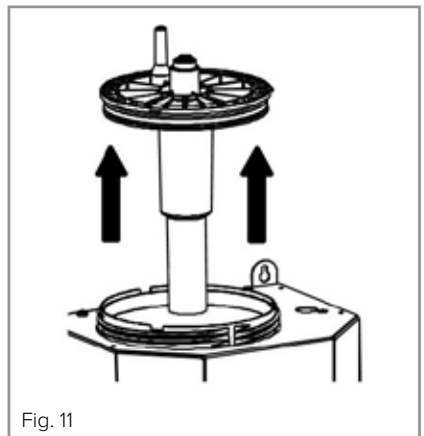
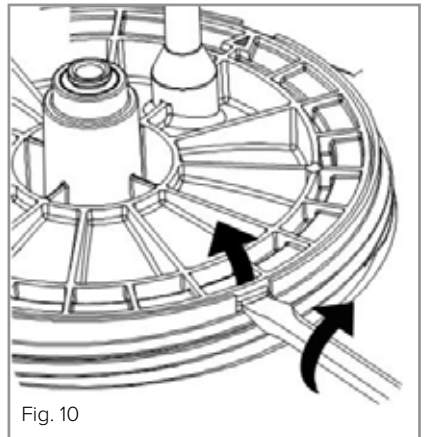
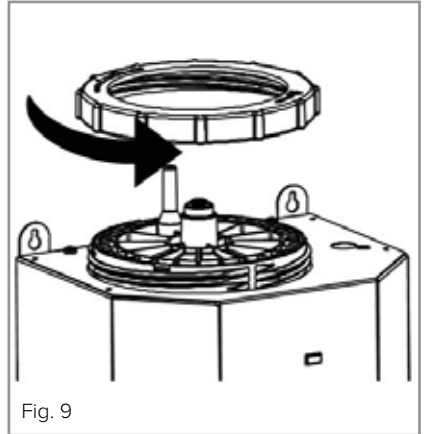

Step 10:

Replace the tank lid, **ensuring the arrow is pointing towards the rear of the unit** as per Fig. 12. Press firmly into place. Ensure that the lid is level and properly seated, as per Fig. 13.

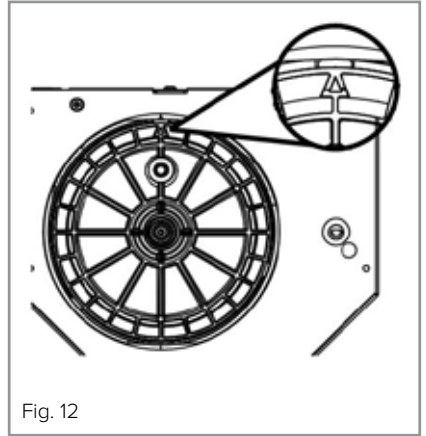

Fig. 12

Step 11:

Replace and fully fasten the tank lid ring as per Fig. 14.

Step 12:

Replace the styrene insulation (F in Fig. 8) and then the boiler lid (E in Fig. 8). Replace the temperature adjustment knob here too (Fig. 15). This may be quite fiddly to get the knob properly seated but you must ensure that it has engaged with the spindle below.

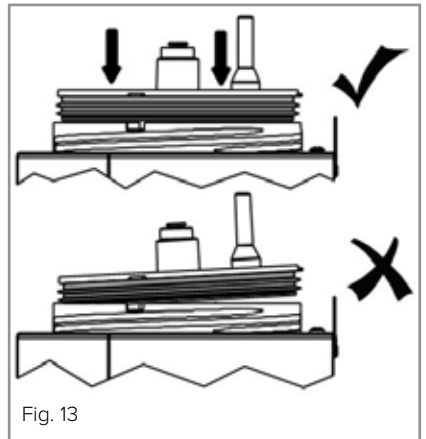

Fig. 13

Step 13:

Return the unit back to its original position. Push the rubber hose marked 'A' in Fig. 16 firmly back into place. Do the same with the water inlet pipe marked 'B'. Ensure that both are firmly re-attached.

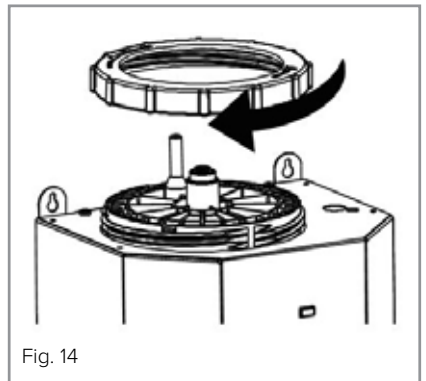

Fig. 14

Step 14:

Turn on the hot (boiled and filtered) water as per page 12 and allow to run until water runs through the spout in a constant stream. When it does, turn the tap lever off.

Step 15:

Plug the boiler in at the mains and switch the power on. Wait approximately 20 minutes for the unit to boil.

Step 16:

Turn on the hot (boiled and filtered) water as per page 12 and flush through at least 5 litres.

Step 17:

Wait approximately 12 minutes for the unit to re-boil. If any off tastes persist after this, repeat steps 16 and 17.

Step 18:

Recalibrate the temperature if necessary.

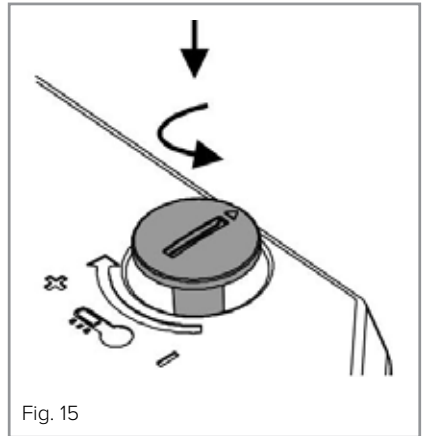

Fig. 15

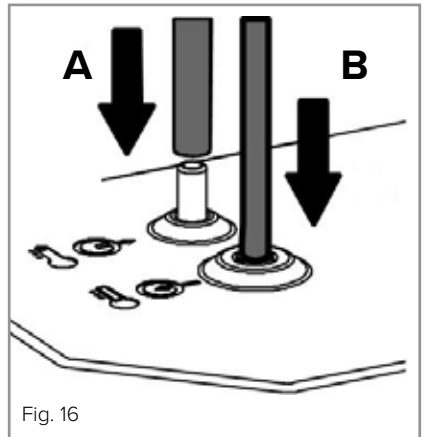

Fig. 16

Draining the system

It may be necessary, from time to time, to drain your boiler system (for example when descaling the system as laid out on the previous 6 pages or during servicing).

The water in the system may be as high as 98°C and as such presents a risk of scalding or injury if not handled with due care and attention. PPE (Personal Protective Equipment) should always be worn when handling the system, particularly should the need arise to drain the boiler system without having allowed for it to cool.

The boiler must be switched off and the contents cooled before draining any stored water. The tank can be made cold by turning off the power and then running the water cold, as laid out in the descaling instructions.

If you wish to allow the unit to cool naturally, please be aware that it would take approximately 8 hours for the contents of a full 98°C tank to cool to a safer temperature of approximately 46°C.

Once the unit has cooled to a satisfactory level, you can follow the drainage procedure laid out in Steps 3 and 4 on page 16 of this manual.

Replacing the filter

It will be necessary, from time to time, to replace the in-line filter with your appliance. Due to the fact that no two installations are the same, usage varies between installs and individual water hardness levels (GB Clark rating) you must use your own judgement regarding when the filter needs to be changed. We recommend replacing the filter every 6 months.

Preparations for replacing the filter

- Before installing the new filter, **it is essential that you switch off the mains power to the boiler unit** and wait for at least 10 minutes for it to cool before continuing. **Do not switch the power back on to the boiler unit until instructed on page 23.**
- Using any filter type not developed and approved for use with this tap and boiler will invalidate your warranty.
- All parts should be removed from their packaging to check that everything required is present and inspected for any transport damage .
- Ensure the left hand (hot, boiled and filtered, water) lever is fully off and that no water is passing through and out of the tap spout before commencing.
- When changing the filter a small amount of residual water may remain in the system. Please have a small bowl and drying cloth to hand.
- Filters must be replaced at the recommended schedule noted on the filter label. Ensure you write on the new installation date.

Please use the guide and diagram (Fig. 17 on page 22) on the following pages to complete the replacement of a water filter.

Steps for replacing the filter

- To remove the old filter, unclip the filter cartridge (C7) from the bracket (C6). Remove the pipes (C4) from both ends of the filter (C7). To remove these pipes from the filter you must firmly push the small white ring on the very end of the filter towards the middle of the filter whilst simultaneously pulling the pipe (C4) away from the filter body (C7). It is normal for some water to be released when the pipes are removed.
- Firmly push-connect the ¼" pipe (C4) between pushfit (C3) and the new filter cartridge inlet. Repeat this from the filter cartridge outlet (C7) to the boiler inlet (E1). **You must respect the direction of flow as indicated on the label.** Visually check the ends of the pipe (C4) are not worn before reconnecting.
- Clip the filter cartridge (C7) into the bracket (C6). Now follow the steps on page 23.

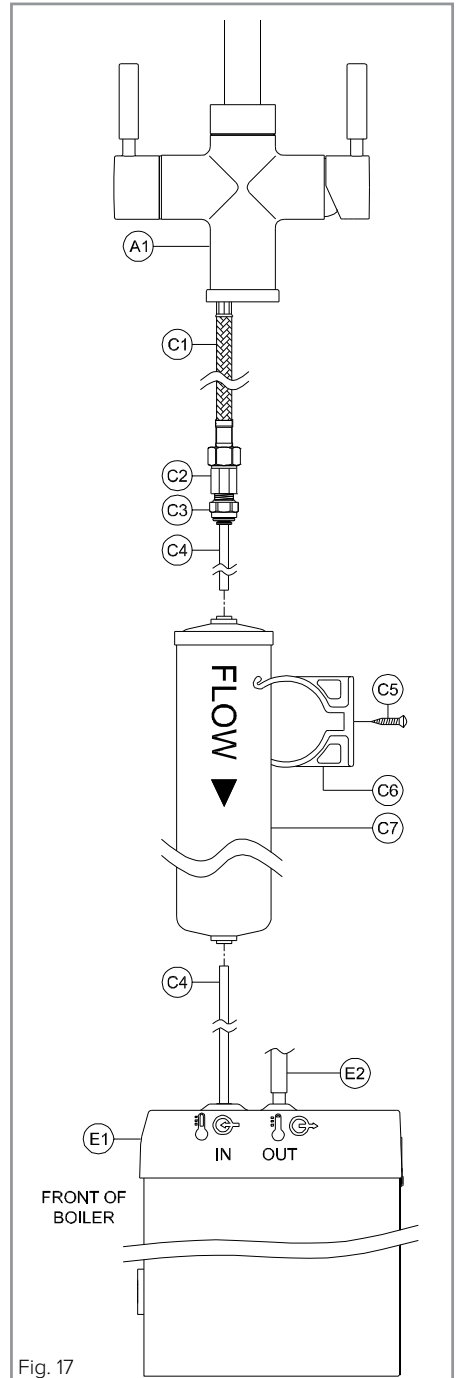

Fig. 17

After installation of a new filter

- Turn on the hot (boiled and filtered) water lever fully. Keep the lever open until all trapped air is expelled and cold (unboiled) water exits the centre channel of the tap spout. Then, flush a further 10 litres of cold (unboiled) water through the filter, boiler and tap. You may notice discolouration to the water at first. This is loose carbon fines from the filter - it is normal, harmless and will pass with flushing.
- Whilst flushing as the system starts to refill, check carefully all new water connections for leaks. Once complete, turn off the left hand hot water lever.
- This filter works best at an approximate flow rate of 2 litres per minute (with the left hand hot water handle fully turned on). This flow rate is determined by the specific incoming cold water pressure to your tap. The filter performance characteristics will be affected if the flow rate is not approximately 2 litres per minute. To change the flow rate through the filter and boiler adjust the cold water isolation valve (B5 in Fig. 18, page 26) using a flathead screwdriver, kitchen measuring jug and a watch whilst the left hand hot water handle is fully turned on.
- Plug in and switch on the boiler, then wait until the water has finished heating fully.
- Re-check for any slower leaks.
- Write the installation date of the filter on its label using a permanent pen.

Installation - Important technical data

Minimum operating pressure (hot): 0.75 bar	Flow characteristics: Domestic hot and cold share outer single flow spout. Boiled water: Through centre spout channel
Minimum operating pressure (cold): 1.5 bar (with filter)	Maximum domestic hot water temperature: 70°C
Maximum operating pressure: 5.5 bar*	Recommended domestic hot water temperature: 46°C

***If these temperatures or pressures are exceeded, even for short periods, damage can result. In such instances a thermostatic mixing or pressure valve should be installed.**

This product is manufactured in accordance with recognised European standards. Please ensure that your tap is fitted in accordance with Local Water Byelaws. Where hot and cold water mix within the tap, then suitable non-return (check) valves should be installed to both the hot and cold supplies to prevent backflow. A pre-installed non return valve on the cold supply flexi-hose (B1) is already supplied (see instructions key - Fig. 18 on page 26).

Ensure that you have suitable domestic hot and cold water supply pressure before installing this product. Hot and cold supply pressures should be as closely balanced as possible for best results. Supply pipes should maintain the maximum diameter until immediately before the fitting. The differential between the hot and cold water supply temperatures should be sufficient to allow correct mixing function.

Installation preparation

Before installing the new tap it is essential that you thoroughly flush through the supply pipes in order to remove any remaining solder, swarf or impurities from your system. Failure to carry out this simple procedure could cause problems or damage to the workings of the tap or boiler. We recommend installing particle filters and isolation valves (B5 in Fig. 18 on page 26) to both the hot and cold feed pipes in an accessible position. This will help any future maintenance.

Shut off your water heating system and ensure that your mains stopcock is closed. Open the lowest hot and cold taps in the house and allow the water to run until fully stopped.

If replacing an existing tap, remove the tap & clean the end of the feed pipes using wire wool, the tap hole area should be free from dirt and sealant. Loosely position the tap and tail pipes to check if any alteration to the existing pipework is required. If this is the case do this now. This tap requires a Ø35mm tap hole and is designed to be installed in a worktop with a maximum thickness of 50mm.

Fig. 18 on page 26 is intended to help you during installation and is referenced throughout the installation instructions.

Required tools:

17mm & 19mm spanner or adjustable spanners

No. 2 pozi-drive screwdriver

Pencil

Scissors/cutters for tubes

A drill and Ø5.0 & Ø5.5 masonry bits (if wall mounting)

Key	Description	Qty supplied
A1	Mixer tap	1
A2	Base plinth	1
A3	Base plinth seal	1
A4	Sink or worktop (max. 50mm)	0
A5	White triangular plate (for steel sinks only)	1
A6	Lower gasket	1
A7	Metal horseshoe	1
A8	Fixing stud	1
A9	Fixing nut	1
B1	Domestic cold flexible hose (including non-return valve)	1
B2	15mm olive	0
B3	15mm nut	0
B4	15mm pipe	0
B5	15mm isolation valve	0
B6	Domestic hot flexible hose (excluding non-return valve)	0
C1	Cold out (to filter & boiler) flexible hose (including seal)	1
C2	3/8" M x 1/4" F adaptor	1
C3	1/4" NPT M x 1/4" pushfit	1
C4	1/4" outside diameter plastic pipe	1*
C5	Filter bracket screw	1
C6	Filter bracket	1
C7	Filter cartridge	1
D1	110° rated hot water hose (from boiler output)	1
D2	3/8" fibre seal	1
E1	Boiler	1*
E2	Flexible boiled water output pipe	1*
E3	Connecting tundish assembly	1*
E4	Flexible drain pipe	1*

*Part supplied with boiler pack

Do not switch on the boiler until instructed.

Fig. 18

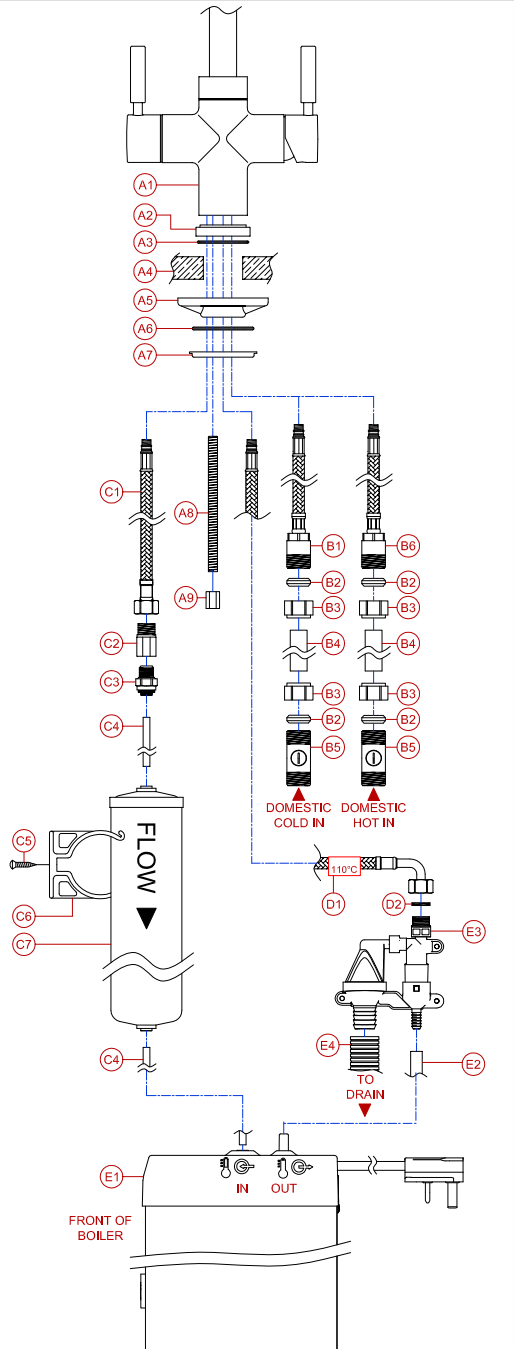

Installation steps - tap

1. Screw the fixing stud (A8) into base of tap (A1) as shown in Fig. 19.
2. Place the base plinth (A2) and base plinth seal (A3) onto the base of the tap (A1).
3. Hand tighten the domestic hot flexi hose (B6) into the position as marked in Fig. 19.
4. Hand tighten the domestic cold flexi hose (B1) as shown in Fig. 19.
5. Hand tighten the cold out flexi hose (C1) as shown in Fig. 19.
6. Hand tighten the 110°C rated hot flexi hose (D1) into the centre inlet as shown in Fig. 19.
7. Place the tap (A1-A3) centrally and straight to the tap hole, passing the fixing stud (A8), flexi hoses (B1, B6, C1, D1) through the tap hole.
8. Pass the lower gasket (A6) and then the metal horseshoe (A7) over the fixing stud (A8). Note: if the tap is to be fitted to a stainless steel sink then the white triangular plate (A5) can be fitted where shown to improve the stability of the tap.
9. Using a 13mm box spanner or small adjustable spanner, tighten fixing nut (A9) onto the fixing stud (A8).
10. Screw pushfit (C3) into adaptor (C2), **we recommend using PTFE**

tape (do not use sealing compound) on the thread of pushfit (C3) to make a good seal without applying excessive force (which may damage the plastic pushfit if overtightened).

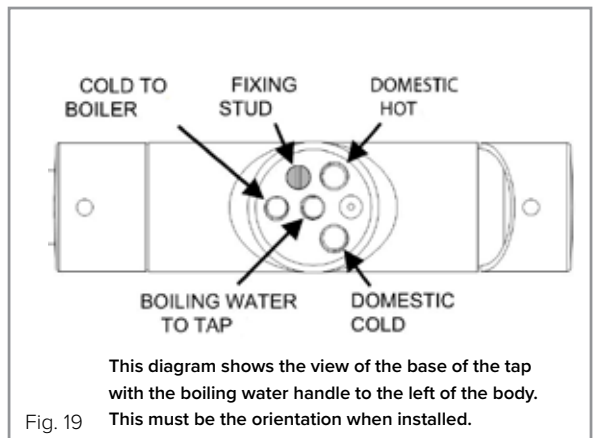

Fig. 19

11. Screw pushfit (C3) and adaptor (C2) into the cold out flexi hose (C1).
12. Connect the cold water flexi hose (B1) to the cold water isolation valve (B5) using a section of 15mm pipe (B4) and compression nuts (B3) and olives (B2). Repeat the process to connect the domestic hot flexi hose (B6) to the domestic hot water supply.

Installation steps - boiler unit

Check that you have the required contents;



Boiler unit



Drain valve



Screw fixing pack



Tube pack (Hot, cold and drain)

Tube lengths (approx.):

Drain tube - 60cm

Water inlet pipe - 120cm

Hot water tube - 60cm

(Mains lead length - 100cm approx.)

Choose a site for the boiler; it is designed to be fitted in a cupboard under the sink. It can stand on a flat level surface or be mounted on the wall inside, whichever is more convenient.

1. Connect the drain valve assembly (E3) to the hot water hose (D1) ensuring that the fibre seal (D2) is in place. You may wish to leave this connection loose until the final position of the valve is known.

When locating the drain valve, please be aware of the following:

- Not kinking the tube (E2) from the boiler terminal to the valve.
- The location of the drain on the sink waste as the tubing needs to have a clear run and not be twisted.
- The location of the boiler relative to the drain valve - a shorter run will result in less heat loss.

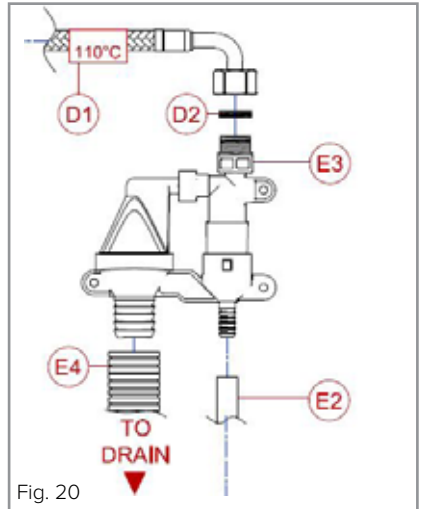

IMPORTANT: THE DRAIN VALVE MUST BE LEVEL. It also needs to be fitted as high as possible. This is to help prevent the possibility of a blocked sink flowing out to the drain valve.

Down loops in the hot hose are permitted provided they are not lower than the drain level of the valve at any point (Fig. 21). If they drop below the level of the valve then the valve will not function correctly.

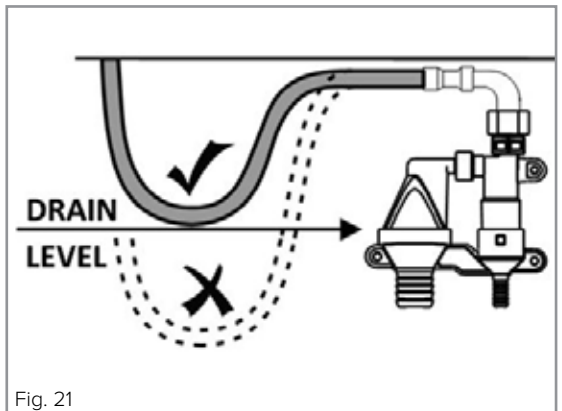

2. Place the boiler unit in its intended position. If the boiler is being mounted on the wall lift off the cover complete with temperature knob (1 in Fig. 22) and the insulation cap (2 in Fig. 22) to expose the mounting holes (3 in Fig. 22). Hold the product **level** in the desired position and mark the holes. The hole centres are 184mm apart. **Ensure that the fastening used is appropriate**

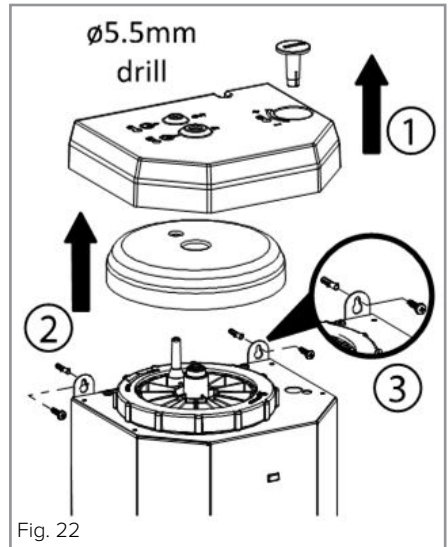

- to the surface that the unit is being mounted to and is capable of handling the product weight, which when full is approx. 4.7kg.** Once the boiler has been mounted in the desired position (if applicable), replace the insulation cap, the cover and the temperature control knob (this may be quite fiddly to get seated but you must ensure that it has engaged with the spindle below).
3. Connect the hot tube (E2 in Fig. 20) from the drain valve to the hot outlet of the boiler (marked 'Out'). The tube needs to have a smooth run with no kinks or sharp bends. This can be cut to suit your installation. **To optimise the performance of this unit, keep this tube's length to a minimum.** Do not extend this tube. Doing so may result in performance issues and/or noise from the drain valve.
4. Insert the cold water inlet pipe (blue) into the boiler inlet (marked 'In') and connect the other end to the filter outlet.

5. Connect the drain hose (E4 in Fig. 20 on page 29) to the sink waste connection as per Fig. 23.

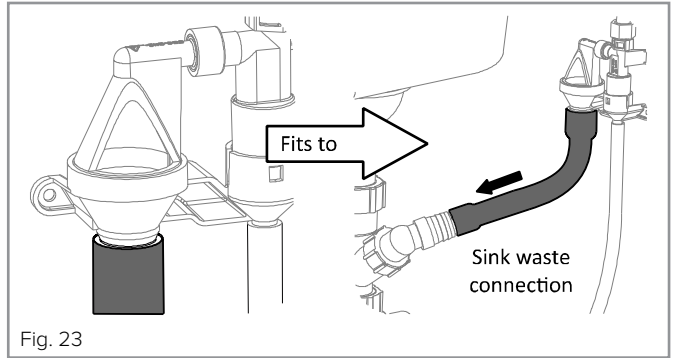

6. Push the hot (boiled and filtered) water tap lever downwards and then pull the lever forwards and leave for approximately 1 minute or until water flows. When it is flowing, plug the boiler in at the mains. Switch on the power at the mains - the red light on the boiler should come on. Return the hot lever to the off position.

Calibration procedure

1. Loosely rotate the temperature knob on the boiler unit until it drops and then press down. You should feel the temperature knob engage with the spindle below. If it does not, remove the temperature knob and turn it upside down to check the position of the spindle slot. Align this with the spindle and try engaging it again.
2. Turn the temperature knob clockwise fully and wait for the boiler to boil freely (this should take approximately 12 minutes from cold).
IMPORTANT: When turned to the maximum position and once the water is fully boiled, the boiling water may come from the tap spout without the handle being turned on. Please exercise extreme caution so as to avoid injury to yourself or others.

3. Whilst the unit is boiling, turn the temperature knob anti-clockwise until you hear a 'click'. The red light on the front will go out.

IMPORTANT: Do not over-rotate the temperature knob - it is limited to $\frac{3}{4}$ of a turn.

4. To check the temperature setting, run the hot tap until the water runs cold and allow the boiler to heat back up. If set correctly, the light on the boiler will extinguish automatically once the water has heated up. You may have to repeat this step a few times to achieve the desired setting.
5. **If the temperature calibration is set too high the unit will boil too often and hot water may be ejected from the tap outlet. Due to atmospheric pressure this setting may need to be adjusted from time to time to optimise the performance.**

Please note: The tap may drip during the calibration process as the drain valve requires time to work.

The following page (page 33) contains a diagram (Fig. 24) showing a finished installation setup. Ensure that the installation you have carried out is similar to this one.

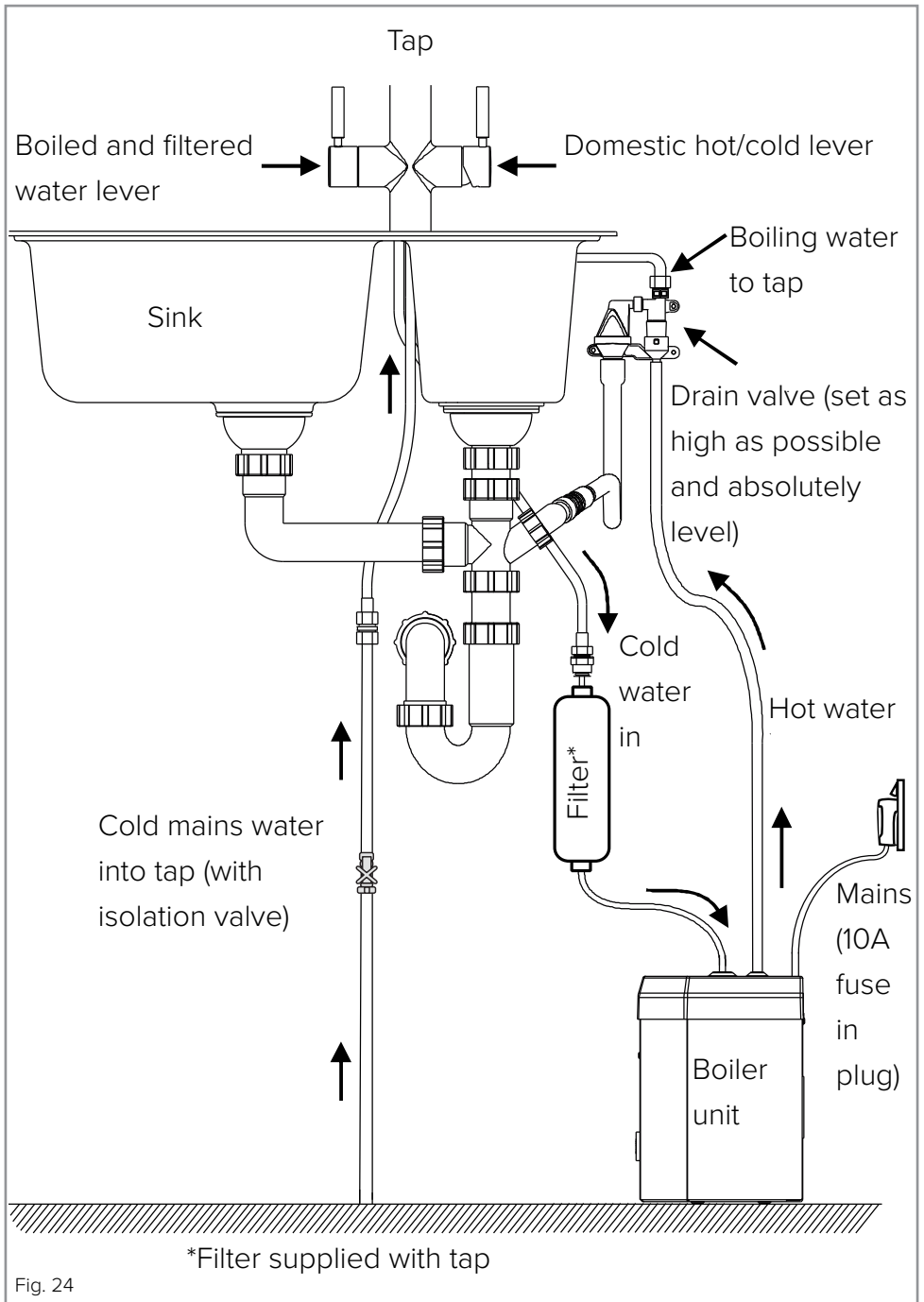

Fig. 24

Technical data (Boiler unit)

Dimensions (mm); H - 238, W - 217, D - 176

Weight when empty; 2.8kg

Weight when full; 4.7kg

Unit capacity; 2.0 Litres

Unit loading; 1000 watts @230V

Supply voltage; 220-240V ac

Inlet connection; ¼” push fit

Boiler outlet; 8mm plain shank

Drain valve; 3/8” BSPP thread

Flow rate; 1.8 Litres/minutes

Time to fill (from empty); 1.0 minute

Time to heat up from cold; 12 minutes

Recovery time; 8 mins

Min. water pressure; 1.5 bar

Max. water pressure; 8.0 bar (5.5 with filter)

Temperature range; 65 – 98°C

Please note: The minimum water pressures for the tap are 0.75 bar for hot and 1.5 bar for cold. The maximum water pressure for the tap is 5.5 bar (with filter).

If the pressures or temperatures quoted on this page are exceeded, even for short periods, premature wear or damage can result.

The installation should be checked periodically for damage.

Electrical information

Warning! This appliance must be earthed.

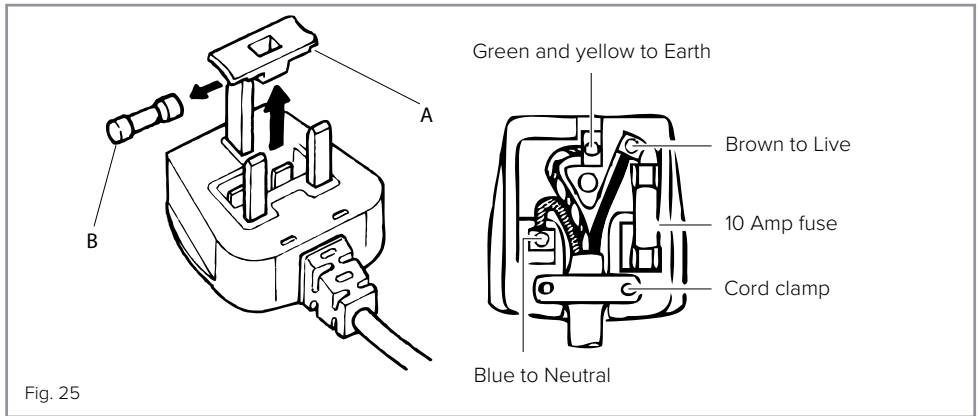

The mains lead of this appliance has been fitted with a BS 1363A 10 Amp fused plug. To change a fuse in this type of plug, follow the steps below:

1. Remove the fuse cover (A) and fuse (B).
2. Fit replacement 10A fuse, ASTA approved to BS 1362 type, into the fuse cover.
3. Replace fuse cover.

Important: Do not use the appliance without the fuse cover in position.

How to connect an alternative plug

If the fitted plug is not suitable for your socket outlet, then it should be cut off and disposed of safely to avoid possible shock hazard. A suitable alternative plug of at least 10 Amp rating to BS 1363 should be used.

As the colours of the wires in the mains lead of this appliance may not correspond with the coloured markings identifying the terminals in your plug, proceed as follows:-

- The wire which is coloured GREEN and YELLOW must be connected to the terminal which is marked with letter (E) or by the Earth symbol \perp or coloured GREEN and YELLOW.
- The wire which is coloured BLUE must be connected to the terminal which is marked with the letter (N) or coloured BLACK.
- The wire which is coloured BROWN must be connected to the terminal which is marked with the letter (L) or coloured RED.

If in doubt regarding the electrical connection of this appliance, consult a qualified electrician. Do not shorten the supply cable, the appliance may require removing for servicing.

IMPORTANT: Ensure that the plug socket is situated in an easily accessible place after installation. We recommend the socket be placed as far away as possible from areas that may leak (e.g. sinks and waste kits).

Troubleshooting guide

The guides on the following pages are intended to help you if your unit is not working satisfactorily, or you have a query regarding performance. Please be advised that this is only a guide and the suggested solutions may not solve the issue(s).

IMPORTANT: Unless otherwise instructed in this manual or the troubleshooting guide, always ensure that the appliance has been disconnected from the mains, the water isolated and that the boiler unit (and any pipework) has been allowed to cool sufficiently. We strongly recommend wearing PPE (Personal Protective Equipment) at all times to protect you from potential hazards such as sharp edges, steam and burns. If any steps involve disconnecting pipework then we also recommend having a vessel and dry cloths to hand in order to catch and clear up any residual water.

Please note that any checks or potential solutions highlighted in red text in the detailed troubleshooting guide are those that should be carried out by a plumber or authorised service agent.

If you are at all uncomfortable performing, or lack confidence/knowledge to carry out, any of the user checks in this guide please contact service using the details at the bottom of this page.

If any of the steps in this guide do not resolve your issue, please disconnect the boiler unit from the power supply and contact service on **0330 311 6585** or email **service.request@proboil.co.uk**.

Troubleshooting guide - basic

Light not on, water is hot.	Unit is up to temperature, light will illuminate again as the unit temperature drops. This is normal.
Light not on, water is cold.	Check that the electrical supply is connected and switched on and that the plug fuse is not blown.
No water flow when tap is operated.	Check that the water supply is on. Please note that there can be a short delay dependent upon how long the unit has been left unattended.
Tap ejects water when heating and appears to be constantly boiling.	The thermostat is set too high. Turn anti-clockwise to reduce set temperature. Re-calibrate (pages 31-32). Allow time for drain valve to work.
Water is not hot enough.	Thermostat set too low. Turn clockwise slightly to increase set temperature. Unit may need re-calibrating (pages 31-32).
Boiled water flow reduced.	Check that tubes and/or pipes are not kinked or pinched. The boiler unit may need de-scaling.

Troubleshooting guide - detailed

Problem	Potential cause	Check	Potential solution
Poor boiling water flow rate	Low water pressure	Check cold water supply is greater than 1.5 bar.	Turn up cold water isolation valve or stop tap.
	Rubber output hose from boiler kinked	Check if hose is partly kinked.	Cut rubber hose to length move away from any object that might interfere with it.
	Boiler inlet flow limiter blocked	Tank inlet (under the push-fit) has a 2mm hole, hold the tank lid to a light source to see if it's clear.	Use a thin needle to clear the blockage though the push-fit.
	Drain tundish blocked / stuck	Check the drain valve is fitted horizontally as recommended. Check the stainless steel ball moves freely inside the valve (shake the part to see if it rattles).	Clean, descale or replace drain valve.
	Boiler scaled	Tank inlet (under the push-fit) has a 2mm hole, hold the tank lid to the light, see if it's clear.	Descal the boiler. Then, use a thin needle to clear the blockage though the push-fit.
	Faulty filter cartridge, or cartridge blocked	If the filter is blocked.	Disconnect the filter, bypass it by connecting the water supply directly to the boiler with no filter to confirm.
No boiling water flow rate	Cold water supply is off	Normal cold water supply is functional by turning on the normal cold water on the tap.	Turn the cold water isolation valve or stop tap on fully.
	No cold water supply due to non-return valve	Non-return valve in the cold water flexible pipe to the tap is assembled backwards or is faulty.	Have your fitter/plumber check the non-return valve in the flexi-tail. Replace if required, otherwise reassemble in the correct orientation.
Black rubber exit pipe blows off the boiler	Rubber pipe is too long or kinked	Check if hose is partly kinked.	Cut rubber hose to length. Move away from any object that might interfere with it. Do not cable tie the hose, it will make descaling the boiler more difficult. Ensure the rubber hose is pushed on fully and is not greasy.

Problem	Potential cause	Check	Potential solution
Boiling water is too cold	Boiler not calibrated	Position of boiling water calibration dial on boiler.	Turn the dial on the top of the boiler clockwise to increase the temperature, see the calibration instructions (p31-32).
	Faulty thermostat or heating element	Neon light on boiler is on when the water inside is flushed fully and is cold but the water is not heating or making boiling sounds.	Contact service as it is likely that the boiler unit needs to be replaced.
	Tank, heating element or thermal probe inside the tank is scaled up	Remove tank lid, inspect for scale.	Descale the boiler using CDA supplied descale solution only, follow the instructions provided (p14-19).
	No power to the boiler	Check the socket is switched on by plugging in a different appliance. Check the fuse in the boiler plug.	Turn on power supply or replace boiler plug fuse.
	Difference between standard performance and expectation	The product is being used as intended.	Run/flush the tap for 5+ seconds before use to allow the parts to warm through. Warm the cup you are using with the "waste/flushing water" (p13). Check you are giving the boiler enough time to re-boil in between uses; if the red light on the boiler is on as you are using it then the water is not fully hot.
Boiling water is too hot	Tank, heating element or thermal probe inside the tank is scaled up	Remove tank lid, inspect for scale. If the boiler is scaled it will boil for longer periods to try to reach the set temperature.	Descale the boiler using CDA supplied descale solution only, follow the instructions provided (p14-19).
	Boiler calibration is set too high	Check if position of boiling water calibration dial on boiler is set too high.	Turn the dial on the top of the boiler anti-clockwise to decrease the temperature, see the calibration instructions (p31-32).
Hot water "runs on" for a few seconds after the handle is turned off	Residual pressure in system	n/a	This is normal - the pressure in the filter and boiler will take a few seconds to disperse once the handle is turned off so the water flow will not stop immediately.

Problem	Potential cause	Check	Potential solution
Hot water takes a few seconds to flow after the handle is turned on	System drains automatically and the pressure is removed from the system	Turn the tap on and time the lag time.	n/a: it is normal for a lag of 1-3 seconds for the filter, boiler and supply hose to re-pressurise and water to flow.
Water is leaking from the drain valve at the front of the tank	Drain plug not tight or damaged	Check the drain plug is tight using a coin.	If the plug is tight but is still leaking replace the drain plug.
Water is leaking from the tank lid	Rubber seal worn not fitted correctly or damaged	Remove the tank lid, check the rubber seal is fitted correctly and is not worn or damaged.	Replace the seal if necessary.
	Tank lid is not fitted correctly	Check the tank lid is pushed in fully, straight and the correct tabs on the lid line up with the tank.	Refit the tank lid, if the leak persists replace the tank lid.
	Lid screw cap is not tight	Check the lid screw cap is tight and not cross threaded.	Unscrew the lid cap and retighten. If the part is damaged replace it.
Water is running out of the drain valve during or after use	Possible dirt or scale build up in drain valve or the part is damaged	Check the drain valve is fitted horizontally as recommended. Check the stainless steel ball freely moves inside the valve (shake the part to see if it rattles).	Clean, descale or replace drain valve
	Difference between standard performance and expectation	Check that the total amount of water exiting into the sink waste does not exceed 100ml per 1000ml dispensed.	It is normal for some water to exit into the waste when the boiled water is running. After the tap is turned off the water in the tap and hose leading to the tap is drained automatically to the waste for reasons of hygiene.
	Drain valve not fitted level	Check the drain valve is level with a spirit level or phone app as per the installation instructions.	Have your fitter/plumber level the drain valve if required. If mounting points are damaged replace the valve.
	Boiler temperature too high	Check that not too much water exits out of the drain valve during the final phase of the boiling period. Check the calibration dial.	Turn the dial on the top of the boiler anti-clockwise to decrease the temperature, see the calibration instructions (p31-32).

Problem	Potential cause	Check	Potential solution
Boiling water coming from the outside channel of the aerator	Aerator disconnected from central spout tube, this could happen if the aerator has been removed to be cleaned.	Unscrew the aerator at the end of the tap, check if the grey plastic aerator is connected fully to the plastic central spout tube connector.	Firmly push the aerator back onto the central spout tube connector. If the aerator is worn or the fit is slack replace the grey aerator.
Slow "normal" hot water flow	Insufficient hot water supply pressure	Check the incoming hot water supply pressure with a pressure gauge and compare the flow rate to the flow pressure graph (p44).	If the tap is fed from a gravity fed (vented) system, have your plumber consider installing a booster pump to the hot water tank output.
	Aerator is scaled up or filled with debris	Unscrew the spout aerator and check for scale build up or debris caused by lack of flushing prior to installation.	Remove, descale and clean the grey aerator at the spout end. Reattach to the inner spout tube firmly and fully.
Tap is leaking water between the body and the base of the spout	Worn or damaged spout o-rings	Remove the spout and check the o-ring condition.	Replace the spout o-rings and grease them, clean the spout and body chamber first.
Water is leaking out near the single lever handle	Single lever valve is damaged	Water is dripping out near the single lever (hot/cold) handle.	Replace the valve.
	Valve is not fully tight in body	Check the valve retaining nut is tight in the body.	Tighten the valve retaining nut fully (apx. 6 NM).
Boiled water is leaking from the spout end (central channel only)	Boiler temperature is too high	Turn off the boiler, and let it cool.	If the dripping stops the boiler calibration is too high, reduce the boiler setting according to the calibration instructions (p31-32).
	Boiled water tap valve is damaged	Water leaks constantly from the spout centre channel.	Replace the quarter turn valve.
	The boiled water handle or safety lock are damaged	Remove the boiled water handle and manually close the valve.	If the leak stops inspect the handle, handle bush and stop ring for damage, replace if damaged. If undamaged realign the parts and screw them together tightly; they may just be loose.

Problem	Potential cause	Check	Potential solution
"Normal" hot and cold water is leaking from the spout end (outside channel only)	Single lever valve is damaged, if this happens early in the product life the tap feed was most likely not flushed on installation.	Water is constantly dripping out of the outside channel of the spout aerator, the dripping stops when the cold and hot water feeds are isolated.	Replace the single lever valve.
Water is leaking from the end of the push-fit on the end of the flexi hose from the tap to the boiler	Push-fit is not tight or no PTFE tape has been used on the thread	Unscrew the grey push-fit fitting, check if PTFE tape has been used.	Add PTFE tape if required then retighten the push-fit fitting (DO NOT OVERTIGHTEN). Replace the push-fit if damaged.
Water is leaking between the blue plastic pipe and either end of the filter	Pipe is not pushed in fully	Check the blue pipe is fully inserted.	Push the blue pipe firmly into the filter until it cannot be pushed any further.
	Blue pipe ends are not cut straight or worn	Despatch the blue pipes from either end of the filter, visually inspect the pipe ends for wear such as scoring.	Cleanly cut off 20mm of blue pipe, squarely using a sharp knife. Replace the blue pipe if necessary.
	Filter pushfit is damaged	Try a new filter to see if the problem persists.	Replace the filter.
Boiling taste or visual is unexpected: (water has dark particles in it)	Filter is new	Flush the filter for 10-20 litres check for dark particle in the water.	Loose carbon is to be expected when the filter is new, this is normal and harmless, and it should pass with flushing. If the dark discoloration continues replace the filter.
(Metallic taste)	Filter has removed the chlorine from the water so the water will be expected to taste different to unfiltered water	If the boiler is new or the filter has been replaced this will be more noticeable and is normal.	Flush the filter and recheck the taste in a week or two.
(Water is cloudy)	Air in water, air introduced from the water supply, during boiling or from dispensing.	Run a glass of water and leave it to settle for 10 minutes. If the water clears then it is due to air bubbles trapped in the water.	n/a
(TCP type taste to water)	Filter life is nearly expired	Check the filter installation date and or usage.	Replace the filter if required.
	Chlorine levels in the water supply have fluctuated	Check water chlorine levels with a DIY test kit, the higher the chlorine level the more noticeable this taste might appear.	n/a
	Boiler or tap is new, non-metallic components react with the chlorine to create this taste	If the boiler and tap is new the taste will be more noticeable and is normal.	Wait a few weeks for the materials to settle then retest. If the taste persists and the product is not newly installed it might be time to change the filter.
(Water tastes of chlorine)	Filter life has expired	Check the filter installation date and or usage.	Replace the filter if required. A replacement can be purchased from CDA.

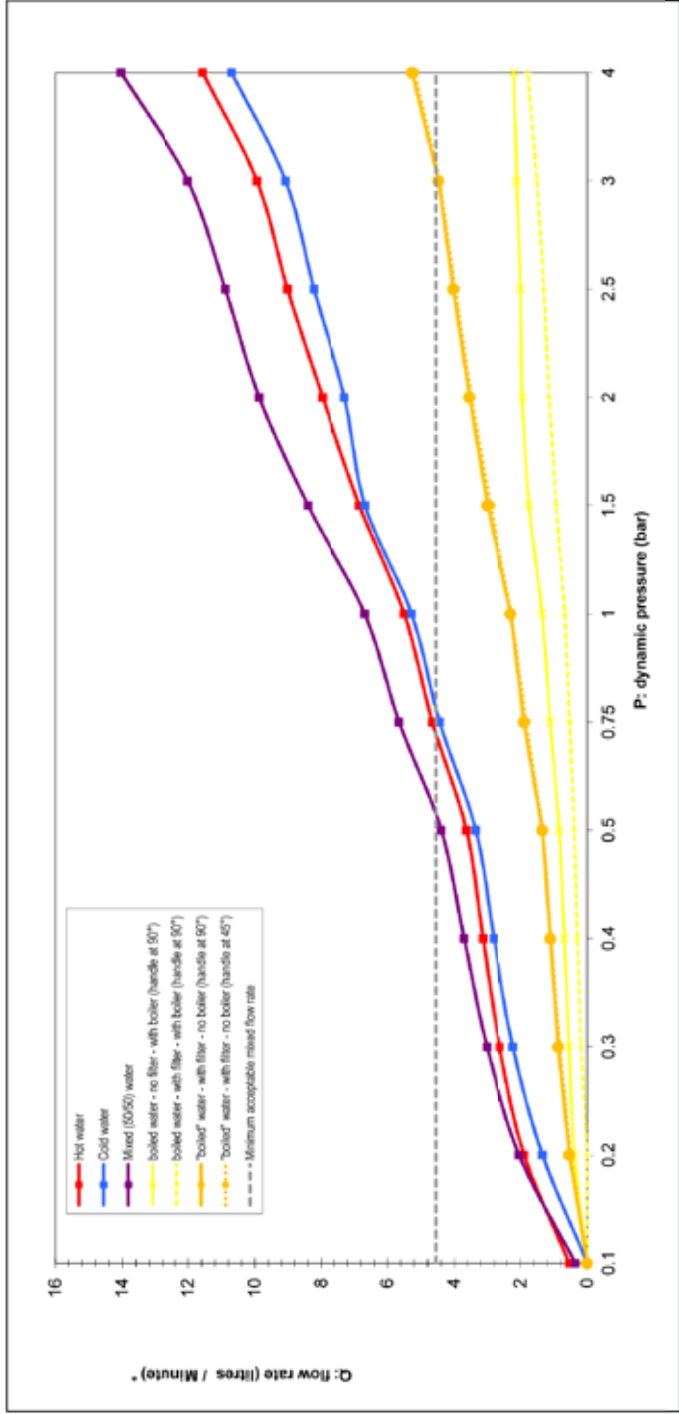

note 1:

note 2:

*Flow rate data shown is correct at the time of testing. CDA reserve the right to amend specifications without prior notice

NOTES:

NOTES:

NOTES:



For boiler service and boiler related queries please contact:

Proboil on **01489 773176**

For tap queries please contact:

The Customer Care Department on **01949 862 012** or email customer.care@cda.eu

For more information on CDA and our products please contact:

The Sales Department on **01949 862 010** or email sales@cda.eu