



# EVCK41 Cylinder Extractor

Installation, use and maintenance



---

## Contents:

3	Important
4	Important information
6	Using your extractor
7	Timer function
7	Clean air function
8	Care and maintenance
8	Removing the grease filter
9	Changing/fitting the charcoal filter(s)
10	Changing the light
11 - 15	Installation
11	Installation preparation - height
13	Ducting and ventilation
14	Mounting the extractor
16	Mains electricity connection
17	Electrical information
17 - 18	Troubleshooting
19	Energy Efficiency Information

# Important

The CDA Group Ltd cannot be held responsible for injuries or losses caused by incorrect use or installation of this product. Please note that CDA reserve the right to invalidate the guarantee supplied with this product following incorrect installation or misuse of the appliance or use in a commercial environment.

This appliance is not designed to be used by people (including children) with reduced physical, sensorial or mental capacity, or who lack experience or knowledge about it, unless they have had supervision or instructions on how to use the appliance by someone who is responsible for their safety.

Under no circumstances should any external covers be removed for servicing or maintenance except by suitably qualified personnel.

## **Appliance information:**

Please enter the details on the appliance rating plate below for reference, to assist CDA Customer Care in the event of a fault with your appliance and to register your appliance for guarantee purposes.

Appliance Model	
-----------------	--

Serial Number	
---------------	--

## **EU Declarations of Conformity:**

This appliance has been designed, constructed and marketed in compliance with safety requirements of EU Directive 2014/35/EU (LVD)

and requirements of EU Directive 2014/30/EU (EMC).

## **IMPORTANT INFORMATION FOR CORRECT DISPOSAL OF THE PRODUCT IN ACCORDANCE WITH EC DIRECTIVE 2012/19/EU.**

At the end of its working life, the product must be taken to a special local authority waste collection centre or to a dealer providing appliance recycling services.

Disposing of a household appliance separately avoids possible negative consequences for the environment and health. It also enables the constituent materials to be recovered, saving both energy and resources. As a reminder of the need to dispose of household appliances separately, the product is marked with a crossed-out wheeled dustbin. 

### **Please note:**

- Under no circumstances should the extractor be connected to any gas ventilation system, flue system or hot air ducting system.
- Do not vent the extractor into an attic or loft space.
- Only house the extractor in rooms with adequate ventilation. Remember that the extractor is powerful and whatever air is extracted needs to be replaced.
- Do not tile the extractor in. It should be removable for service or maintenance.
- Do not use silicone sealant to secure the hood to the wall.
- You must be able to isolate the extractor from the mains electrical supply after installation.

- 
- This extractor has been designed to be used in a room with a volume of less than 36m<sup>3</sup>.
  - Steam cleaners must not be used when cleaning this appliance.
  - The performance of your extractor will vary depending on a number of factors. These include: type of extraction, length of ducting, room volume, ventilation available and cleanliness of the filters.

# Using your extractor

For best performance, you should switch on the extractor 15 minutes before starting to cook and leave it to run for approximately 15 minutes after the end of cooking (you can use the timer function, detailed on page 7, for this).

## Control Panel (Fig. 1)

A - Light button

B - Intensive speed button

C - Speed 3 button

D - Speed 2 button

E - On (speed 1) and off button

## To switch the extractor lights on or off

- Press the light button (A).

## To switch on the extractor and change the speed

- Press button 'E' to switch the unit on. Adjust the speed using buttons 'B', 'C' & 'D'.
- You may notice that the intensive speed (speed 4) indicator flashes when it is selected. This is not a fault (see page 18 for more information).

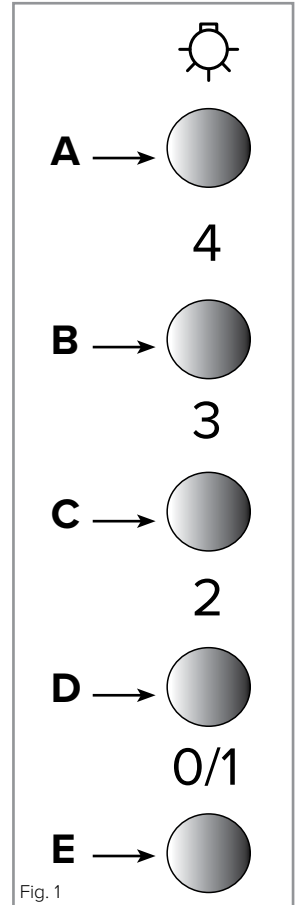

Fig. 1

### **To activate the timer function**

- Press and hold the desired speed button for approximately 5 seconds to activate a **15 minute timer** for that speed. The selected speed's indicator should flash. Hold the same button for approximately 5 seconds to cancel the timer. **Please note that the intensive speed automatically switches off after approximately 6 minutes** (see page 18 for more information).

### **To activate the clean air function**

- This extractor is equipped with a clean air function that runs the motor for 10 minutes every hour to help keep the air in the kitchen refreshed.
- To activate the clean air function, touch and hold buttons 'D' and 'E' whilst the appliance is off (on standby). Buttons 'D' and 'E' will flash whilst the motor is not running to indicate that the function is active.
- To switch off the clean air function, simply press button 'E'.

### **To switch the extractor off**

- If the extractor is on speeds 2, 3 or 4 press button 'E' to revert to speed 1. Then, press button 'E' again to switch the unit off. If the extractor is already on speed 1, press button 'E'.

## Care and maintenance

**IMPORTANT: DO NOT PERFORM MAINTENANCE OR CLEANING OF THE EXTRACTOR WITHOUT FIRST SWITCHING OFF THE ELECTRICITY SUPPLY.**

### Cleaning

You should use a non-abrasive cleaner. Any abrasive cleaner (including Cif) will scratch the surface and could erase the control panel markings.

You can clean your extractor effectively by simply using a dilute solution of water and mild detergent and drying to a shine with a clean cloth.

### **IMPORTANT:**

**Always protect surfaces immediately beneath the extractor (such as a hob) with clean, dry towels or similar cushioning items before carrying out any cleaning or maintenance in case of falling parts/items.**

### Removing and cleaning the grease filter

The grease filter should be kept clean to minimise the risk of fire. At least once a month you should remove and clean the grease filter with hot soapy water. You can also wash the grease filter in a dishwasher, ensuring that you place it in an upright position to prevent damage from other items in the dishwasher. After rinsing and drying, replace the filter. **Cleaning the grease filter in the dishwasher may lead to discolouration. This is normal and does not constitute a fault with the appliance.**



**Please note:** After 30 hours of use the light button will flash to signal that the filter needs to be cleaned. With the extractor off, press and hold the lamp button until it stops flashing to reset after cleaning.

To remove the grease filter, lift the catch on the handle on the grease filter. It will release at the handle side. Lower it towards you slightly and then remove it completely. To replace the grease filter, repeat the steps in reverse.

### **Changing the charcoal filter (re-circulating only) - Fig. 2**

To ensure best performance of your extractor, you should replace the charcoal filter every four to six months, depending on use. To attach a new charcoal filter, first remove the grease filter as described above. Remove any old charcoal filter that is in place by removing the securing screw. Take a new charcoal filter and fit it into position behind where the grease filter sits. Use the screw in the filter aperture to hold the charcoal filter in place. Then, re-fit the grease filter.

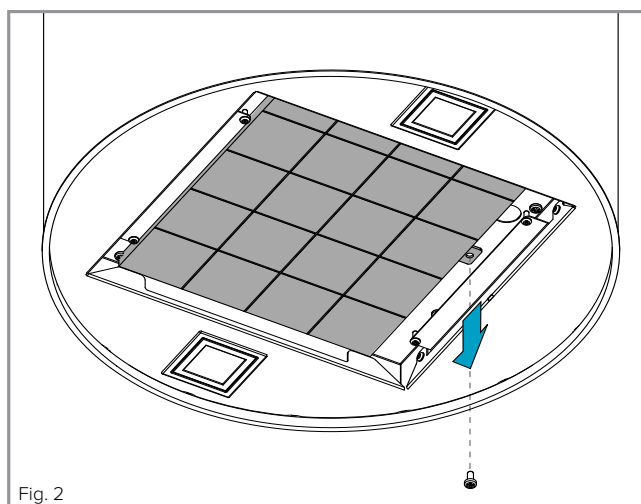

---

## Changing the light bulbs

If one or more of your LED units fail, please contact CDA Customer Care using the contact details below to arrange a service visit.

### **Contact CDA Customer Care**

A: Customer Care Department, The CDA Group Ltd, Harby Road,  
Langar, Nottinghamshire, NG13 9HY

T: 01949 862 012

F: 01949 862 003

E: [customer.care@cda.eu](mailto:customer.care@cda.eu)

W: [www.cda.eu](http://www.cda.eu)

# Installation

When installing this product we strongly recommend you seek the help of another individual. This product may have some sharp edges. Please take care and wear adequate PPE when handling.

## Installation preparation - height

When the extractor is to be installed above an **electric hob**, the minimum distance between the hob and **the bottom edge of the extractor** must exceed 650mm.

When the extractor is to be installed above a **gas hob**, the minimum distance between **the bottom edge of the extractor** and hob must exceed 750mm.

**If the instructions provided with your gas hob state that the required distance between the hob and extractor must be greater than our measurement, then that is the distance that should be observed; this is a legal requirement and may lead to your hob being disconnected from the gas supply and the installation being reported under RIDDOR (the height should be measured from the top of the burners).**

**IN THE ABSENCE OF ANY INSTRUCTIONS SUPPLIED WITH THE GAS HOB, THE MINIMUM DISTANCE BETWEEN THE HOB AND EXTRACTOR MUST BE AT LEAST 760mm. The width of any hob must not be greater than the width of the extractor installed above it.**

There are images below showing the extractor dimensions (Fig. 3) and an exploded view of the installation components. (Fig. 4). These are intended to help with installing the extractor.

Taking into account the extractor dimensions, and the advice regarding installation height as per page 11, roughly mark the screw hole positions for the ceiling bracket (shown in Fig. 5).

Ensure that you are happy with where the extractor will be and the height it will sit at above the hob or surface below.

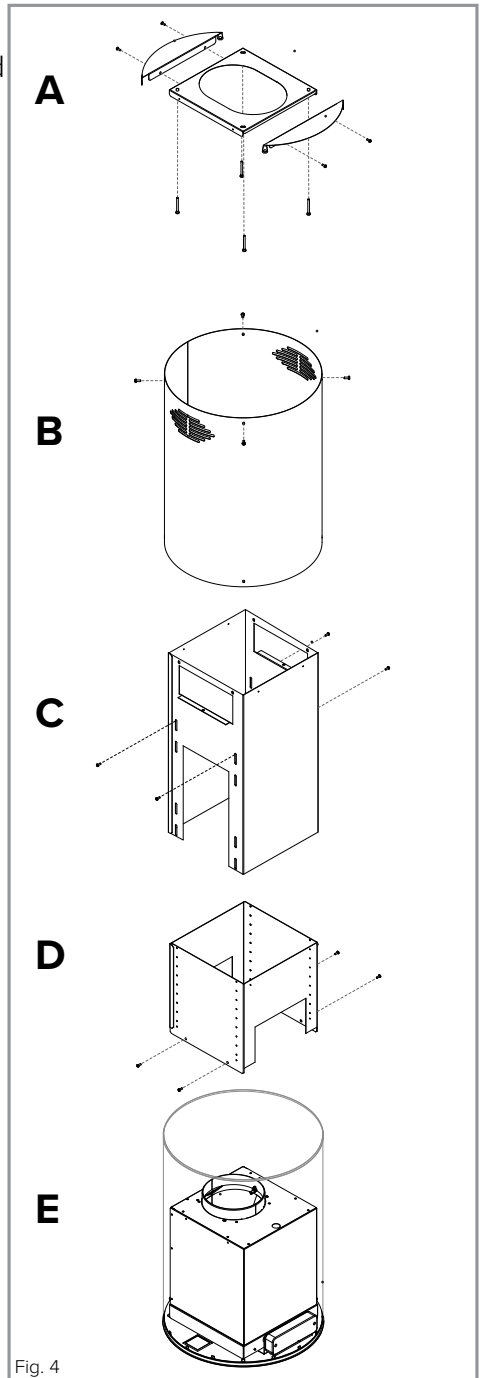
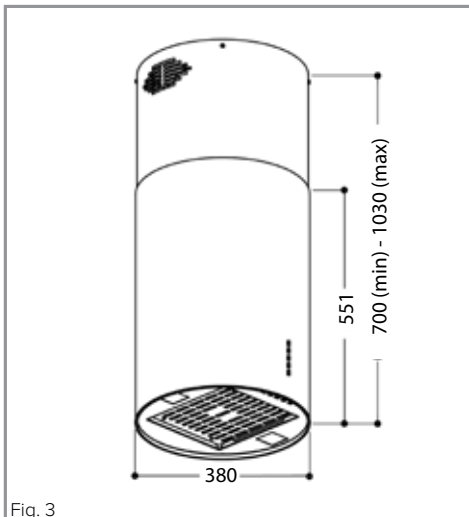

# Ducting and ventilation

For best performance and lowest noise output, we recommend the use of 150mm ducting. You can also use smaller diameter ducting but this will reduce performance and potentially increase the noise level of the extractor whilst in use. In general, the less ducting you use (i.e. distance and bends) the more efficient your extractor will be.

You may wish, at this stage, to fit the ceiling bracket (Fig. 5). Use fixings (e.g. wall plugs) suitable for the surface to which the extractor is to be mounted.

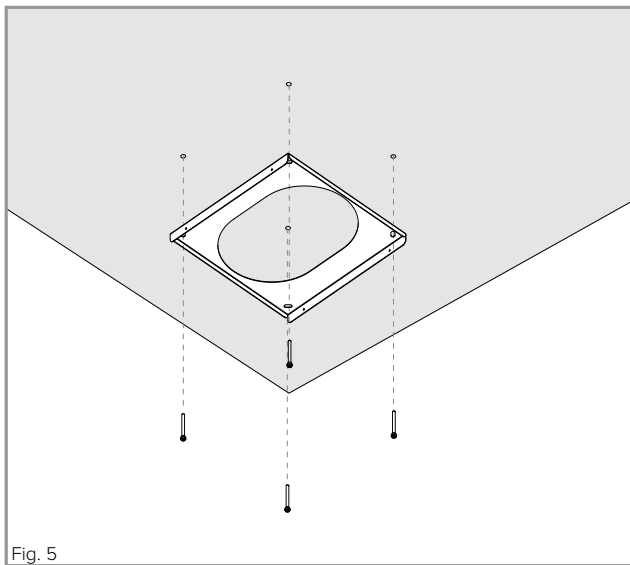
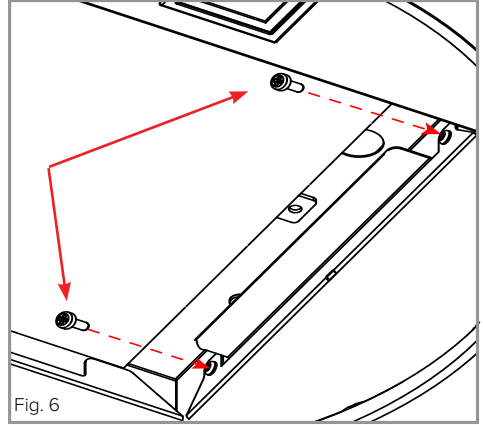

Fig. 5

**Before cutting/drilling through any surfaces, ensure that adequate measures have been taken to ensure no electrical cables or similar lie above/behind.**

# Mounting the extractor

Remove the motor group and housing by first removing the four screws holding the group within the body. Two of these screws are pictured in Fig. 6. There are two more on the opposite side.



Raise the motor group and housing slightly and undo the cable connections that connect the wiring to the motor group, as per Fig. 7. Remove the motor group from the extractor body.



Attach the motor group and housing to the lower frame piece (D in Fig. 4 on page 12) as per Fig. 8.

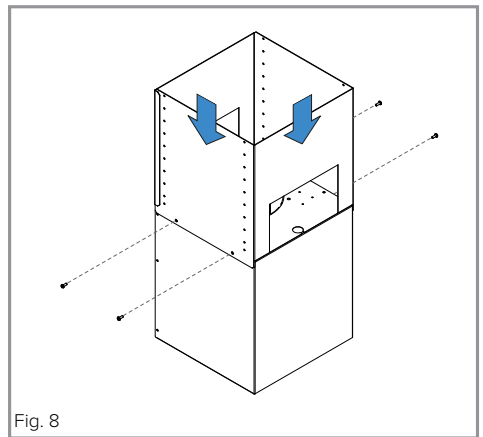

Attach the upper frame piece (C in Fig. 4 on page 12) to the ceiling bracket and fit the chimney piece support brackets as per Fig. 9.

Attach the lower frame piece and motor group to the upper frame piece at the required height as per

Fig. 10. There are lots of screw holes on the lower frame piece to help you achieve the correct installation height.

If you have not already done so, remove the chimney piece and peel off the protective film. Carefully place the chimney piece back inside the extractor body.

With the help of at least one other individual, lift the extractor body up to meet the frame. Whilst one supports the body, reconnect the cable connectors that you disconnected as per Fig. 7.

Re-attach the motor group and housing to the extractor body using the screws you removed as per Fig. 6.

Raise the chimney piece and secure it to the chimney bracket support pieces, as per Fig. 11.

Ensure that everything is secure.

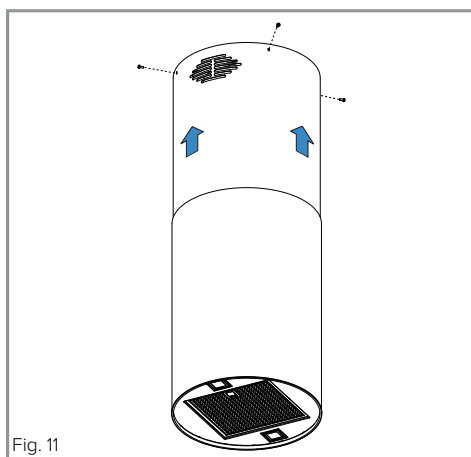
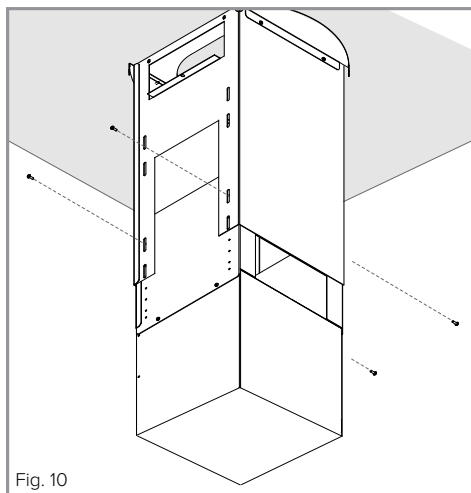
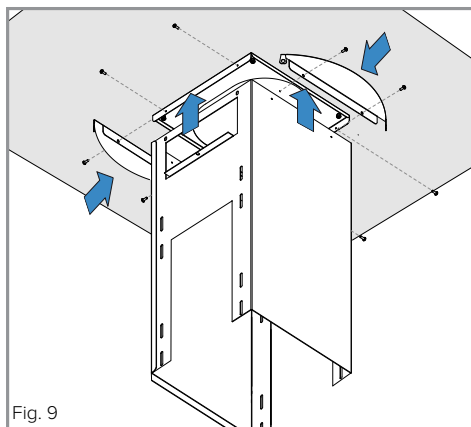

# Mains electricity connection

**THIS APPLIANCE COMES WITH A 3A PLUG BUT CAN BE CONNECTED TO THE MAINS SUPPLY BY A COMPETENT PERSON, USING FIXED WIRING VIA A DOUBLE POLE SWITCHED FUSED SPUR OUTLET AND PROTECTED BY A 3A FUSE.**

We recommend that the appliance is connected by a qualified electrician, who is a member of the N.I.C.E.I.C. and who will comply with the I.E.E. and local regulations.

The wires in the mains lead of this appliance are coloured in accordance with the following code:

**BLUE = NEUTRAL, BROWN = LIVE, GREEN+YELLOW = EARTH**

As the colours of the wires in the mains lead for the appliance may not correspond with the coloured markings identifying the terminals connecting to the fused spur, proceed as follows:

- The wire which is coloured blue must be connected to the terminal marked N (Neutral), or coloured black.
- The wire which is coloured brown must be connected to the terminal marked L (Live), or coloured red.
- The wire which is coloured green and yellow must be connected to the terminal marked E (Earth) or coloured green or green and yellow.

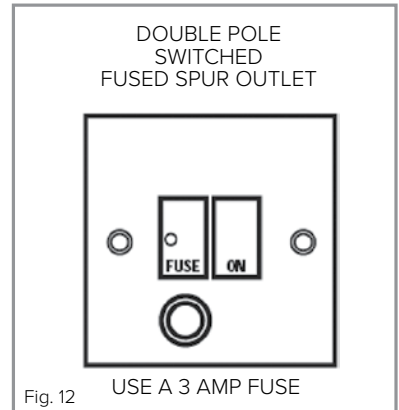

Fig. 12



Assembly and electrical connection should be carried out by competent personnel.

**Do not mount the isolation switch behind the chimney section. It is a requirement that you must be able to isolate the extractor from the mains electrical supply after installation.**

## Electrical information

Mains electrical voltage: 220 – 240Vac.

Total rated power consumption: 278W

## Troubleshooting

### **If your extractor is not working:**

1. Check that the mains supply has not been switched off.
2. Check that the fuse in the spur has not blown.

### **If your lights are not working:**

1. Check that the mains supply has not been switched off.
2. Check whether the extractor still extracts on any speed. If not, check the fuse, as above. If the lights still do not work, contact CDA Customer Care using the details on page 18.

(continued on page 18)

---

**If you notice speed 4 reverting to speed 3 after approximately 6 minutes:**

This is not a fault. Regulations issued by the European Commission in January 2015 dictate that internal motor extractors with a maximum air capacity higher than 650m<sup>3</sup>/h must be equipped with a timer device that automatically switches the speed from '4th', or intensive, to 3rd after 6 minutes of operation.

**If the light button is flashing:**

This is not a fault. After 30 hours of usage the light button will flash to signal that the grease filter needs to be cleaned. Press and hold the light button to reset after cleaning.

If any of the potential resolutions in this guide do not resolve your issue, please contact CDA Customer Care using the contact details below.

**Contact CDA Customer Care**

A: Customer Care Department, The CDA Group Ltd, Harby Road,  
Langar, Nottinghamshire, NG13 9HY

T: 01949 862 012

F: 01949 862 003

E: [customer.care@cda.eu](mailto:customer.care@cda.eu)

W: [www.cda.eu](http://www.cda.eu)

## Energy Efficiency Information

Attribute	Symbol	Value	Units
Model Identification		EVCK41	
Annual Energy Consumption	$AEC_{Hood}$	56	kWh
Time increase factor	f	1.00	
Fluid Dynamic Efficiency	$FDE_{Hood}$	28.4 (A)	
Energy Efficiency Index	$EEL_{Hood}$	57 (B)	
Measured airflow at Best Efficiency Point	$Q_{BEP}$	344.5	$m^3/h$
Measured Pressure at Best Efficiency Point	$P_{BEP}$	444	Pa
Maximum airflow	$Q_{MAX}$	739	$m^3/h$
Measured electric power at Best Efficiency Point	$W_{BEP}$	150	W
Nominal lighting power	WL	3	W
Average illumination of the lighting system on the cooking surface	$E_{Middle}$	206	Lux
Measured power consumption in standby	$P_S$	0.45	W
Measured power consumption off mode	$P_O$	0	W
Sound power level	$L_{WA}$	57	dBA
Grease Filter Efficiency	$GFE_{Hood}$	90 (B)	%
Lamp efficiency	$LE_{Hood}$	44 (A)	%

E & O E. All instructions, dimensions and illustrations are provided for guidance only. CDA reserve the right to change specifications without prior notice.



**For service or queries relating to your product please contact:**

The Customer Care Department on **01949 862 012** or email [customer.care@cda.eu](mailto:customer.care@cda.eu)

**For more information please contact:**

The Sales Department on **01949 862 010** or email [sales@cda.eu](mailto:sales@cda.eu)

**Customer Care Department.** The CDA Group Ltd, Harby Road, Langar, Nottinghamshire, NG13 9HY  
T: 01949 862 012 F: 01949 862 003 E: [customer.care@cda.eu](mailto:customer.care@cda.eu)